



Teileliste und Naeheinrichtungen  
Parts List and Sewing Equipment

**868**

**DÜRKOPP ADLER AG**

Postfach 17 03 51, D-33703 Bielefeld • Potsdamer Str. 190, D-33719 Bielefeld  
Telefon +49 (0) 5 21/ 9 25-00 • Telefax +49 (0) 5 21/ 9 25 24 35 • [www.duerkopp-adler.com](http://www.duerkopp-adler.com)

Ausgabe / Edition: <b>01/2010</b>	Aenderungsindex Rev. index: <b>04.0</b>	Printed in Czech Republic	Teile-Nr./Part.-No.: <b>0791 868801</b>
--------------------------------------	--	---------------------------	--

*Alle Rechte vorbehalten.*

Eigentum der Dürkopp Adler AG und urheberrechtlich geschützt. Jede, auch auszugsweise Wiederverwendung dieser Inhalte ist ohne vorheriges schriftliches Einverständnis der Dürkopp Adler AG verboten.

*All rights reserved.*

Property of Dürkopp Adler AG and copyrighted. Reproduction or publication of the content in any manner, even in extracts, without prior written permission of Dürkopp Adler AG, is prohibited.

**Copyright © Dürkopp Adler AG - 2010**

Inhaltsverzeichnis	Tafel / Table	Contents
Armwelle	1	Upper shaft
Armwelle-schaltbare nadelstangen		Upper shaft-needle bar rocking mechanism
Antrieb Arm- und Unterwelle, Rastkupplung	2	Upper and bottom shaft drive, Safety clutch
Fadenhebel	3	Thread lever
Fadenhebel-schaltbare nadelstangen	4	Thread lever-needle bar rocking mechanism
Antrieb Nadeltransport	5	Needle feed drive
Alternierender Obertransport mech., Fussfuehrung	6	Alternating foot top feed mech., Foot guide
Antrieb Untertransport	7	Bottom feed drive
Untertransport	8	Bottom feed
Fusslueftung Handhebel	9	Top roller lift hand lever
Transportsaeule	10	Middle post
Fusslueftung Kniehebel	11	Top roller lift knee lever
Fuesslueftung pneu.	12	Top roller lift pneu.
Hubverstellung	13	Skipping foot lift pneumatic
Grosser Greifer mit Spule	14	Large hook with bobbin
Uebergrosser Greifer mit Spule	15	Oversized hook with bobbin
Greifersaeule rechts	16	Hook post right
Greifersaeule links	17	Hook post left
Luefterfinger, Saeulendeckel	18	Releasing hook, Hook cover
Fadenabschneider	19	Thread trimmer
Spuler	20	Winder
Spannungsplatte Einnadel mech.	21	Tension plate 1 needle mech.
Spannungsplatte Einnadel pneu.	22	Tension plate 1 needle pneu.
Spannungsplatte Zweinadel mech.	23	Tension plate 2 needles mech.
Spannungsplatte Zweinadel pneu.	24	Tension plate 2 needles pneu.
Stichverstellung 1 Stichlaenge	25	Stitch adjustment 1 stitch length
Stichverstellung 2 Stichlaengen, Stichverkuerzung	26	Stitch adjustment 2 stitch lengths, Stitch reduction
Verriegelung mech., pneu.	27	Backtacking mech., pneu.
Magnetventileinheit, Taster	28	Solenoid valve unit, Push-buttons
Zentralschmierung, Oelstandanzeige	29	Central lubrication, Maintenance indicator
Arm, Fadenfuehrung, Integr. Diodennaehleuchte	30	Arm, Thread guide, Sewing light LEDs
Arm, Fadenfuehrung, Integr. Diodennaehleuchte - schaltbare nadelstangen	31	Arm, Thread guide, Sewing light LEDs -needle bar rocking mechanism
Armdeckel ECO	32	Arm cover ECO
Armdeckel CLASSIC	33	Arm cover CLASSIC
Grundplatte	34	Bed plate
Naehleuchte Halogen	35	Sewing lamp halogen
Naehantrieb FIR 1147-F752.3 und FIR 1148-F752.3	36	Motor FIR 1147-F752.3 and FIR 1148-F752.3

Inhaltsverzeichnis	Tafel / Table	Contents
Teilesatz fuer FIR 1147-F752.3	37	Part set for FIR 1147-F752.3
und FIR 1148-F752.3		and FIR 1148-F752.3
Naehantrieb EFKA DC1550/DA321G	38	Ministop EFKA DC1550/321G
Teilesatz DC1550/DA321G,		Part set DC1550/DA321G,
Bedienfeld, USB Memory Stick		Control panel, USB memory key
Teilesatz	39	Part set
Gestell	40	Stand
Wartungseinheit	41	Maintenance unit
Beipack	42, 43	Accessories
Eindiodennaehleuchte	44	Sewing lamp LED
Nahtmittenfuehrung	45	Seam centre guide
Nahtmittenfuehrung schwenkbar		Swivelling seam centre guide
Kantenanschlag		Edge guide
Kantenanschlag		Edge guide
Rollenanschlag		Roller stop
Bandfuehrung	46	Tape guide
Fusslueftung pneu.	47	Foot lift pneu.
Fusslueftung el. pneu.		Foot lift el. pneu.
Index		Index
Stichplattenschieber		Slide
Befestigungsteile fuer Naheinrichtung		Fastening parts for sewing equipment
Naheinrichtungen		Sewing equipment
Bauschaltplan		Wiring diagram
Pneu. Geraeteplan		Pneumatic circuit plan

**Teileliste und Naheinrichtungen**  
**Parts List and Sewing Equipment**

**868**

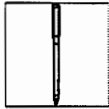

Einnadel-Maschine  
single needle machine

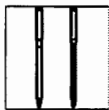

Zweinadel-Maschine  
two needle machine

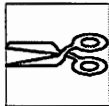

mit Fadenabschneider  
with thread trimmer



ohne Fadenabschneider  
without thread trimmer



grosser Greifer  
large hook



uebergrosser Greifer  
oversized hook

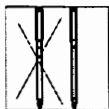

Einnadel-Maschine/rechte Saeule  
single needle machine/right column

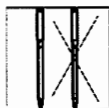

Einnadel-Maschine/linke Saeule  
single needle machine/left column



kleben/stick

N

nicht einzeln lieferbar/not available as separate part

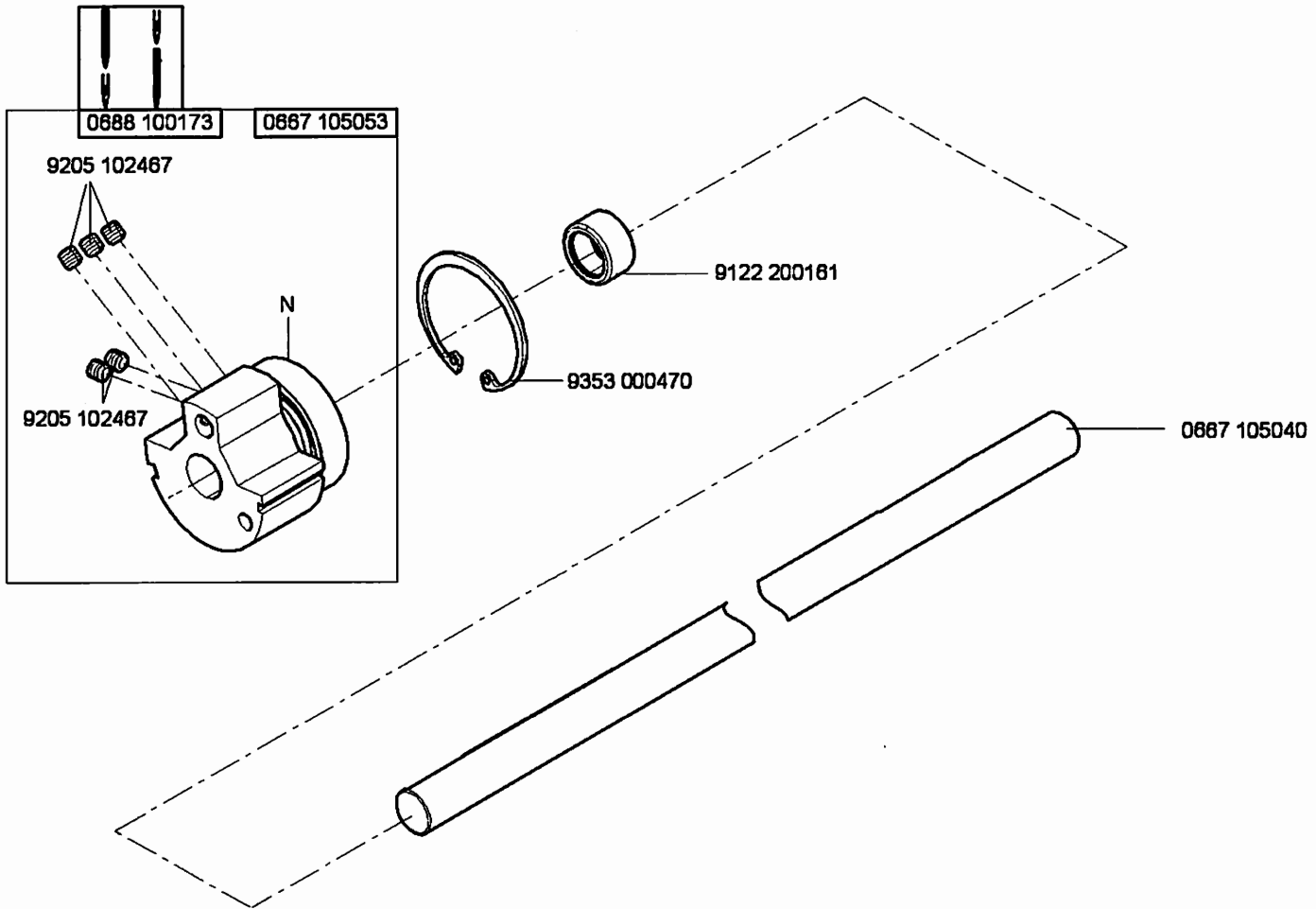

N - nicht als Einzelteil lieferbar  
not available as separate part

Cl. 868

Ausgabe/Edition 8.2008

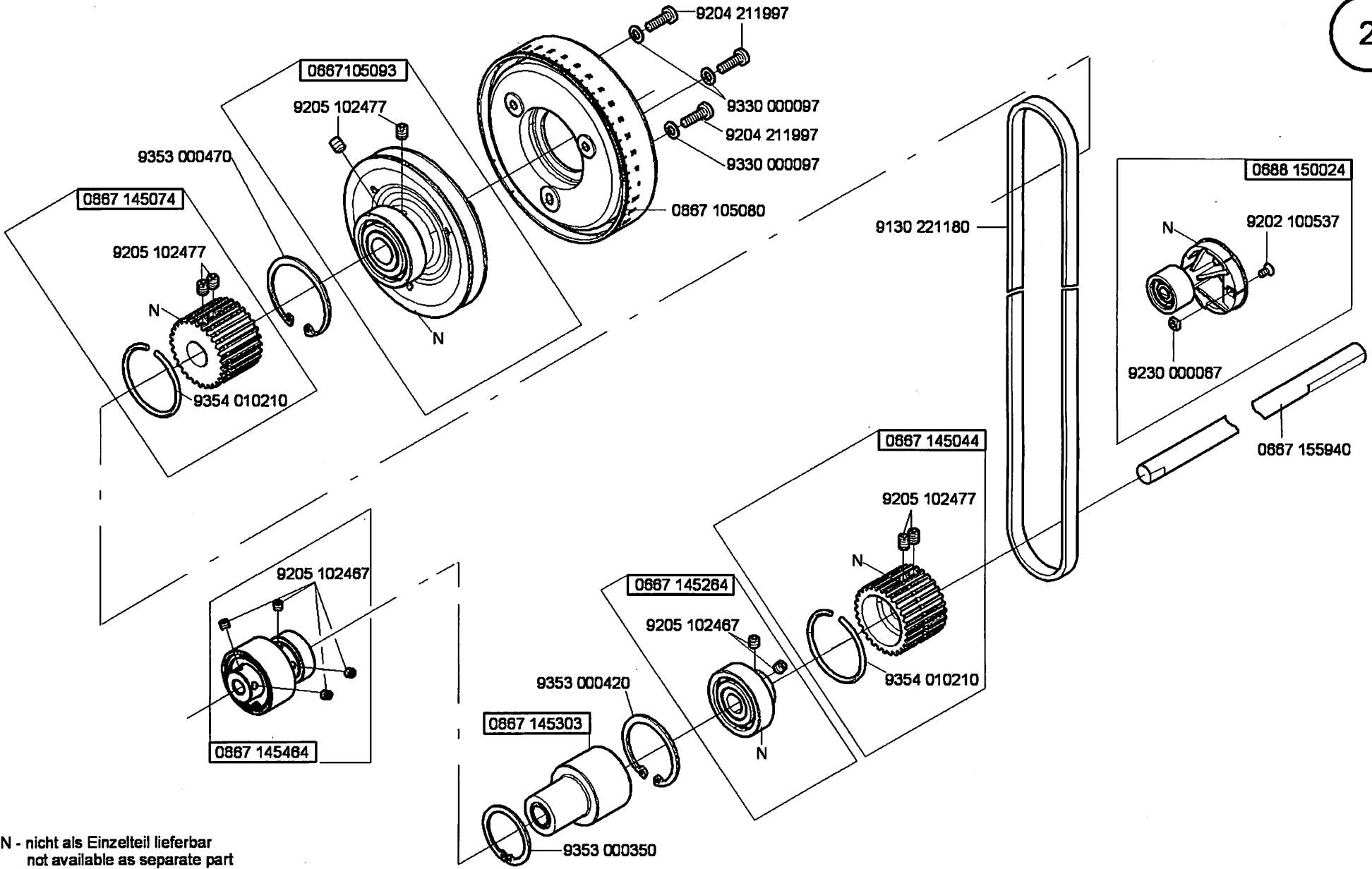

N - nicht als Einzelteil lieferbar  
not available as separate part

Cl. 868

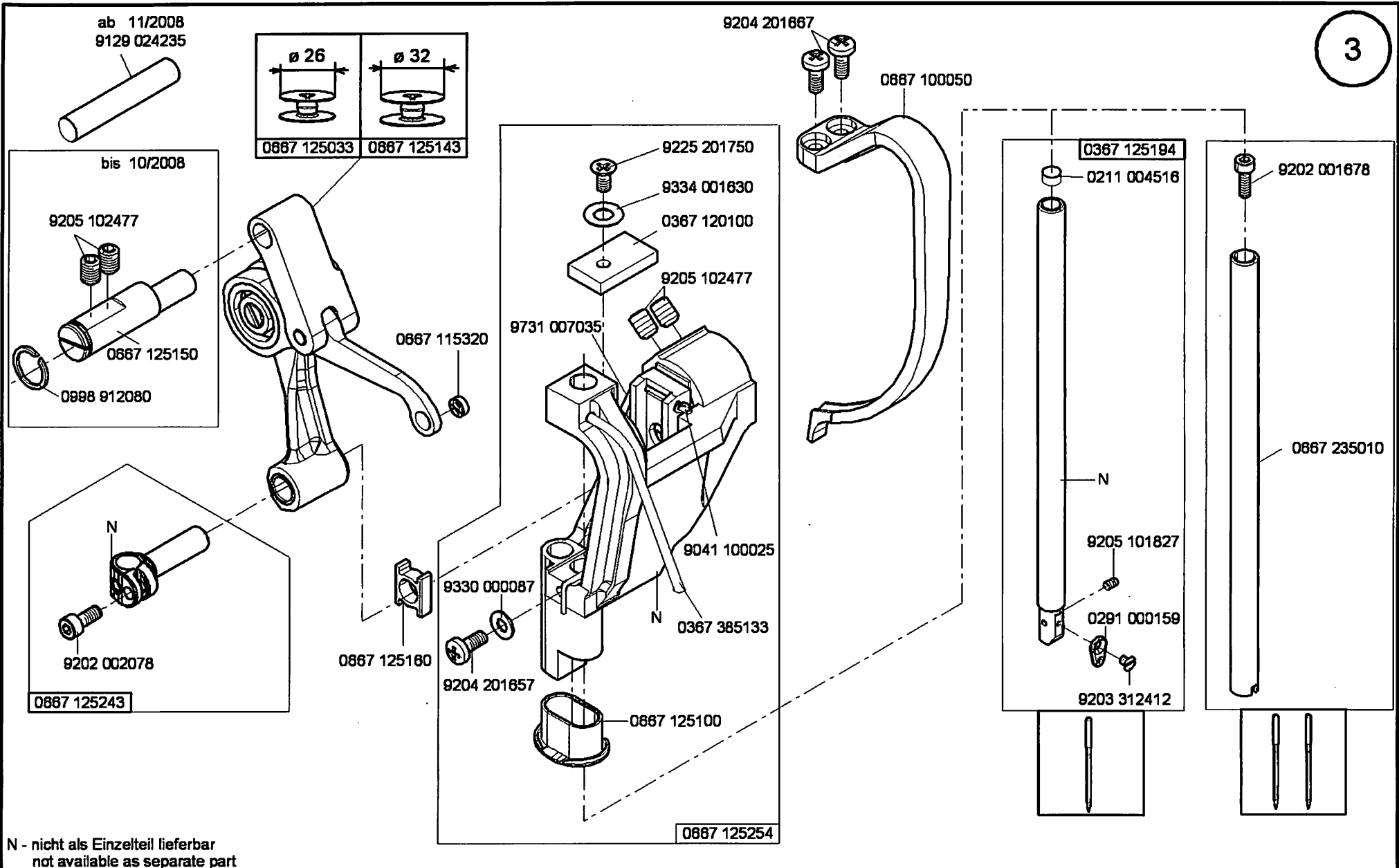

N - nicht als Einzelteil lieferbar  
not available as separate part

Cl. 868

Ausgabe/Edition 9.2008



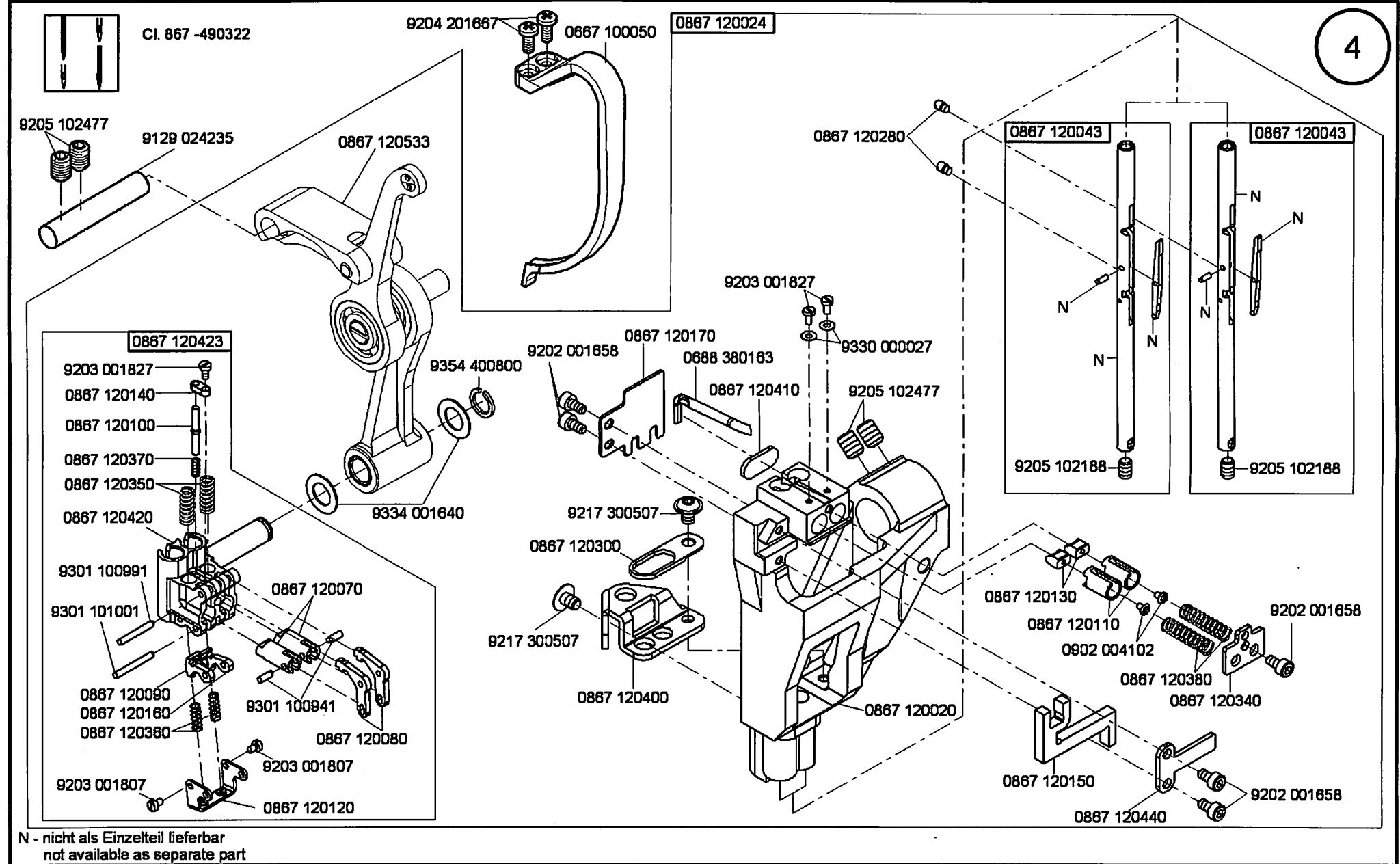

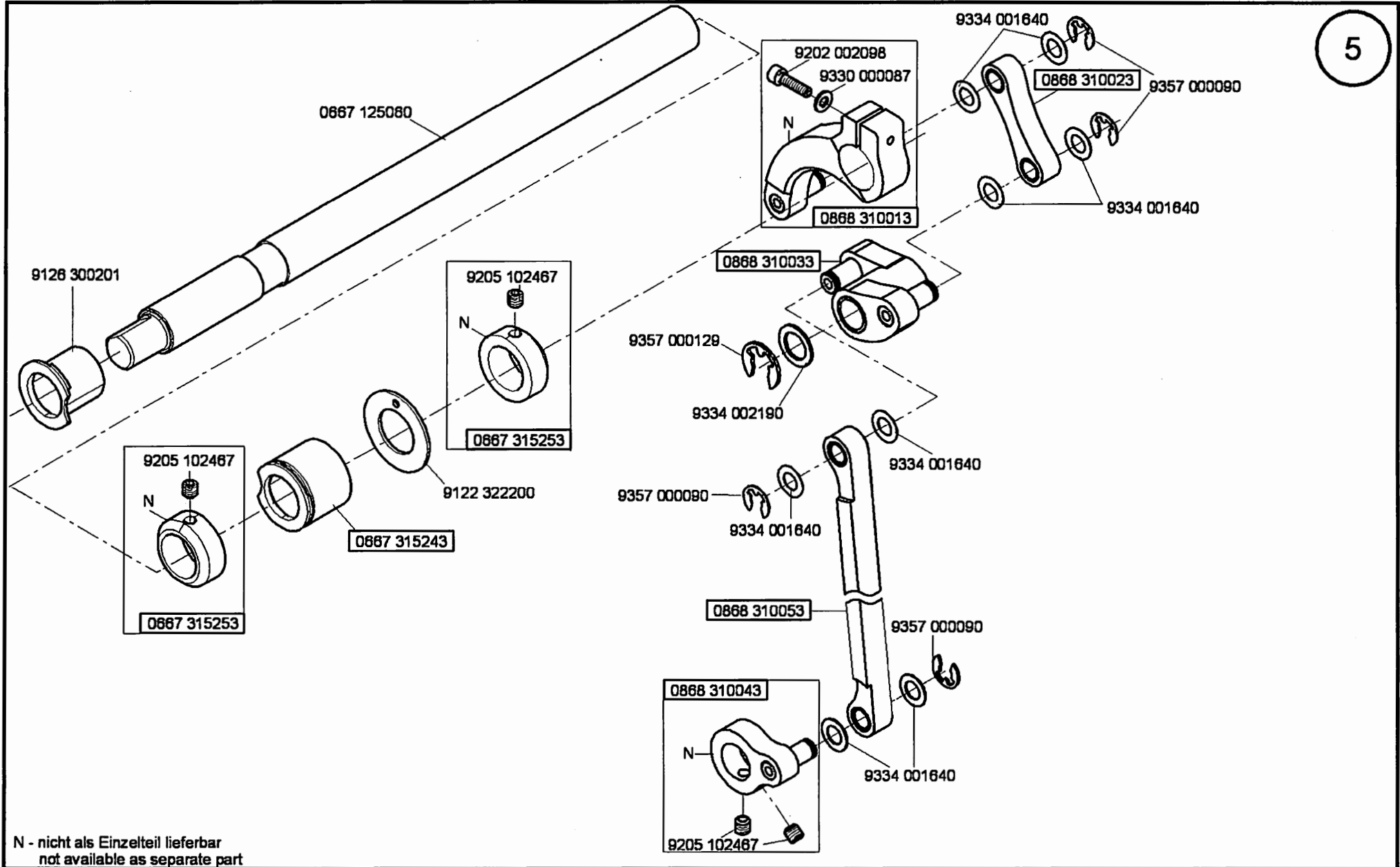

N - nicht als Einzelteil lieferbar  
not available as separate part

Cl. 868

Ausgabe/Edition 8.2008

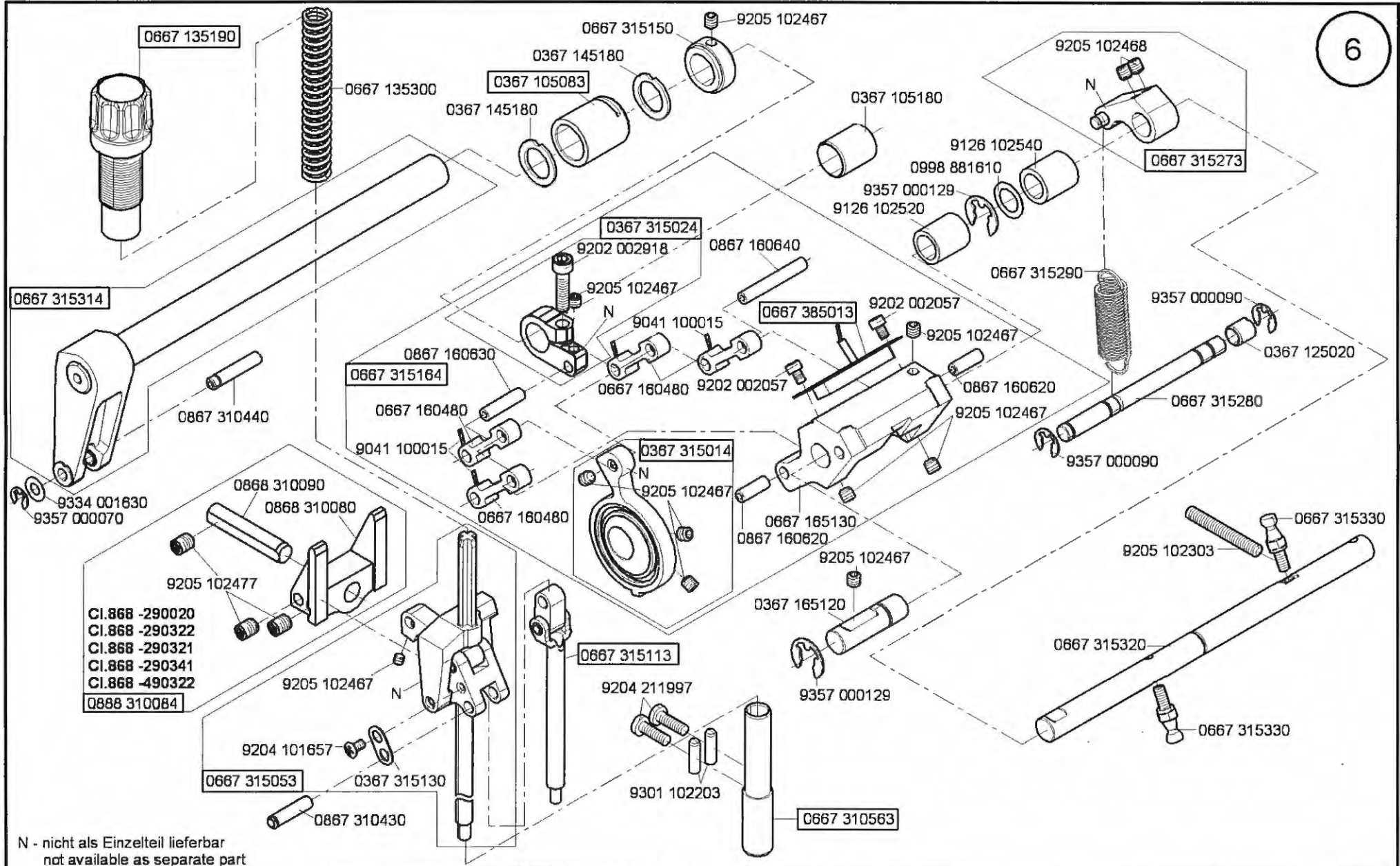

N - nicht als Einzelteil lieferbar  
not available as separate part

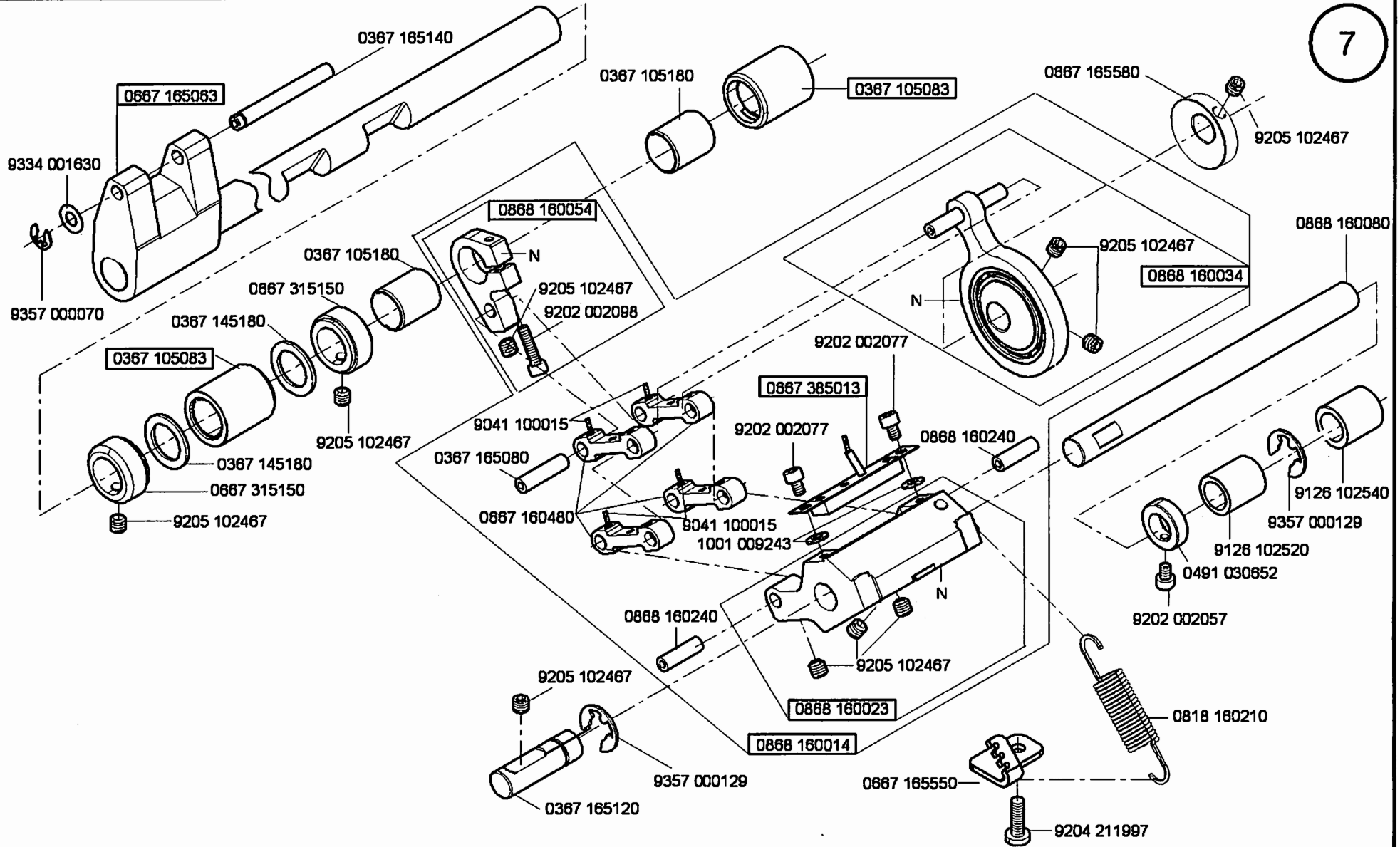

N - nicht als Einzelteil lieferbar  
not available as separate part



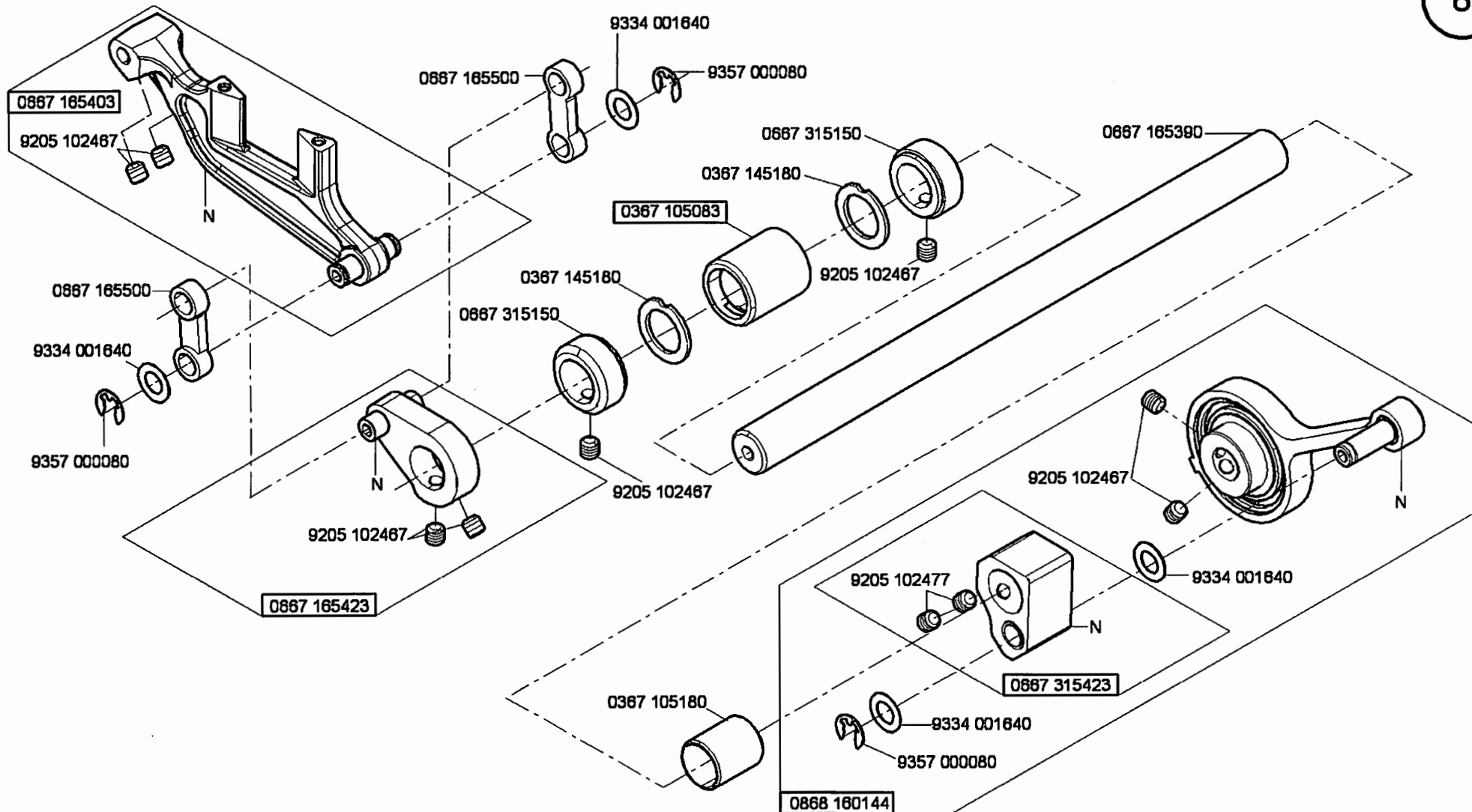

N - nicht als Einzelteil lieferbar  
not available as separate part

Cl. 868

Ausgabe/Edition 11.2008

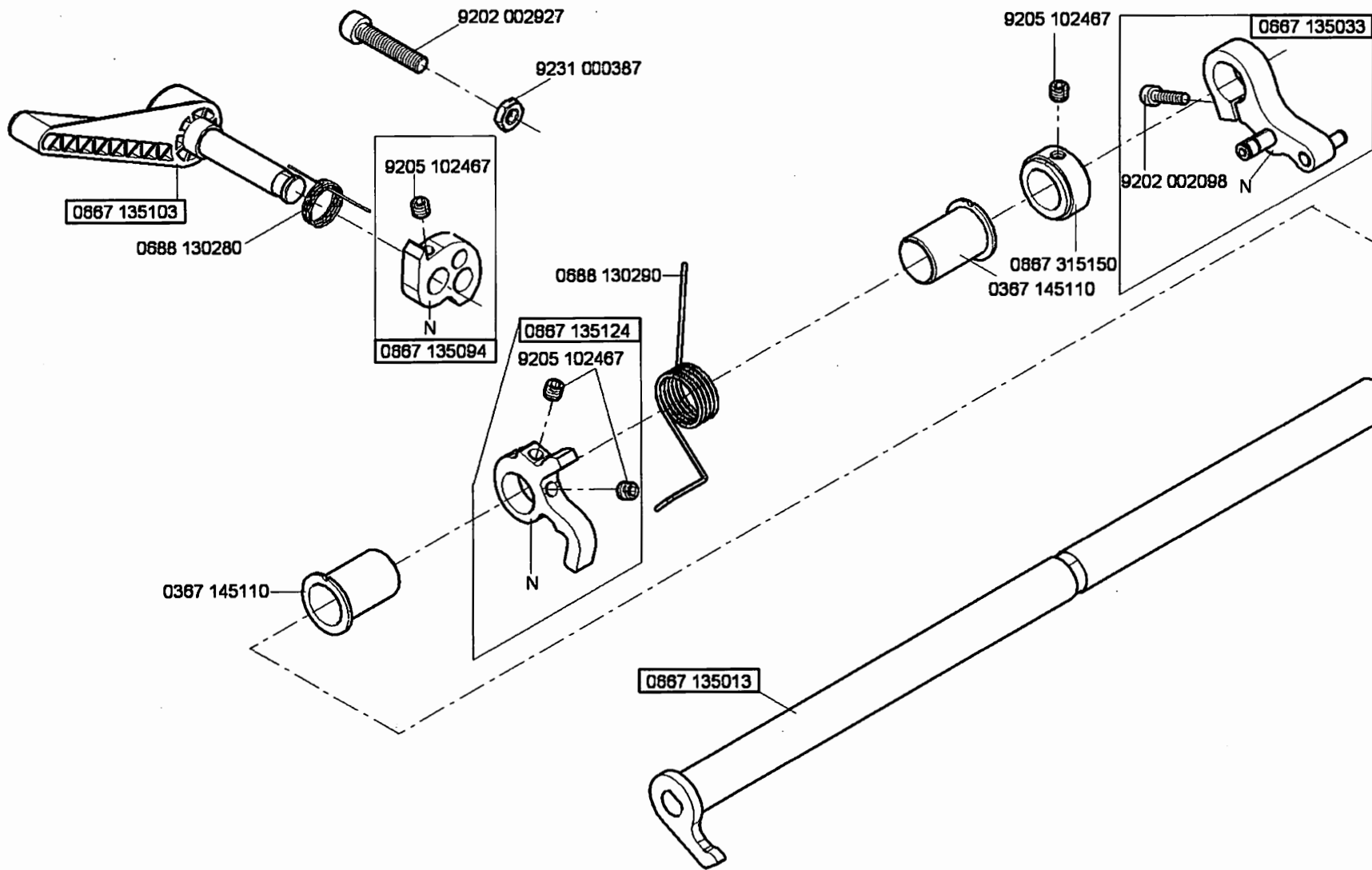

N - nicht als Einzelteil lieferbar  
not available as separate part

Cl. 868

Ausgabe/Edition 8.2008

From the Library of Superior Sewing Machine & Supply LLC

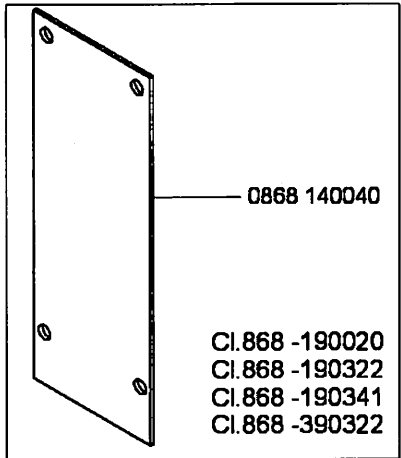
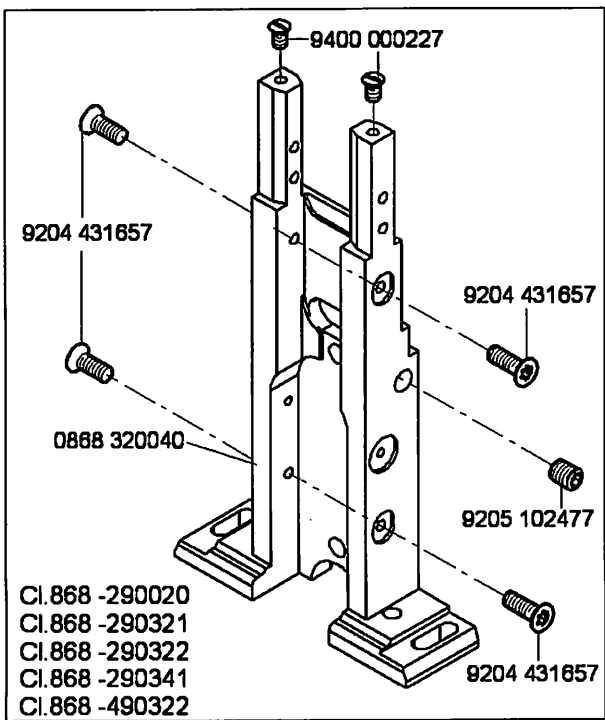

N - nicht als Einzelteil lieferbar  
not available as separate part

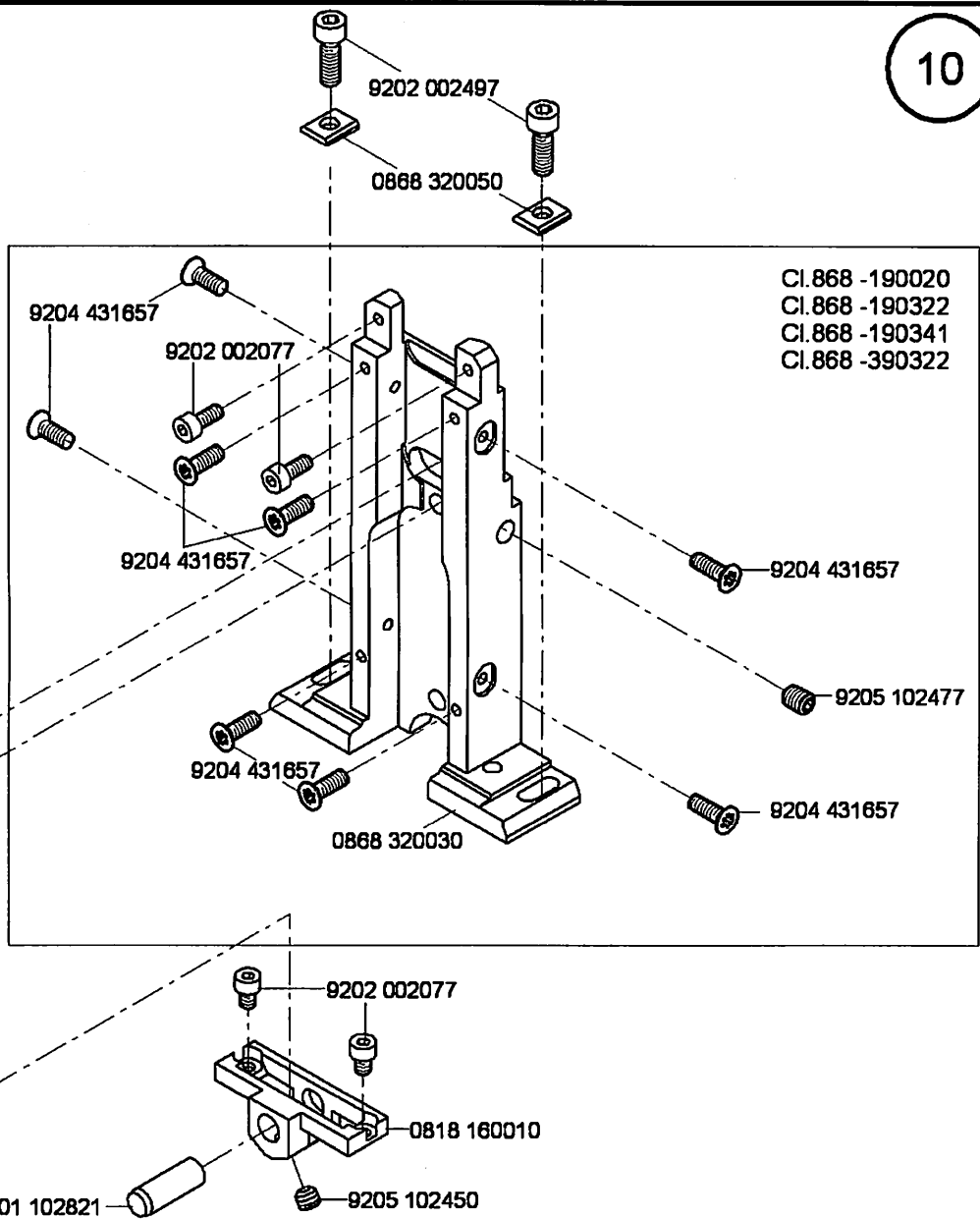

CI. 868



Cl. 868 -190020  
Cl. 868 -290020

11

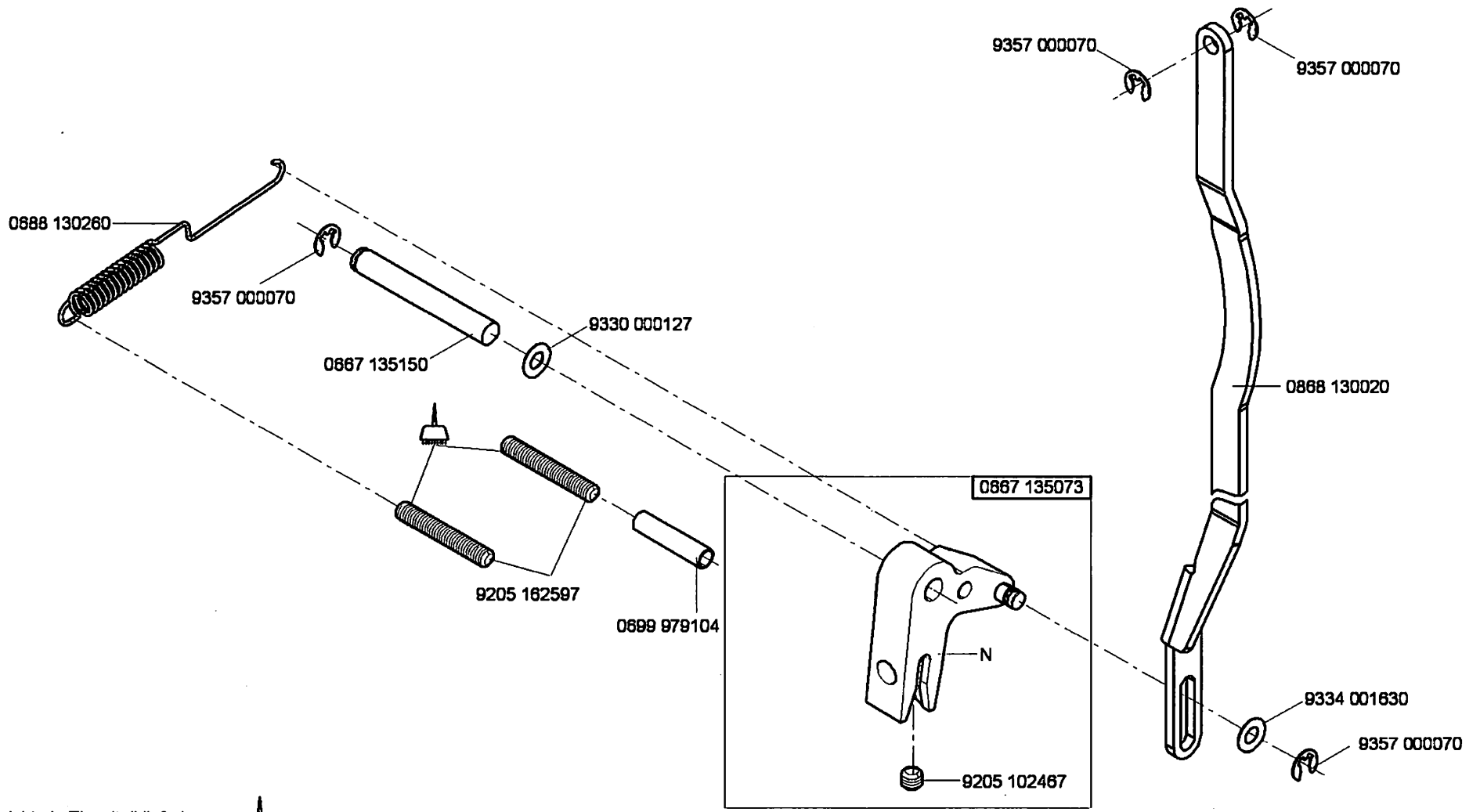

N - nicht als Einzelteil lieferbar  
not available as separate part  -kleben -stick

Cl. 868

Ausgabe/Edition 11.2008



- Cl.868 -190322
- Cl.868 -190341
- Cl.868 -290321
- Cl.868 -290322
- Cl.868 -290341
- Cl.868 -390322
- Cl.868 -490322

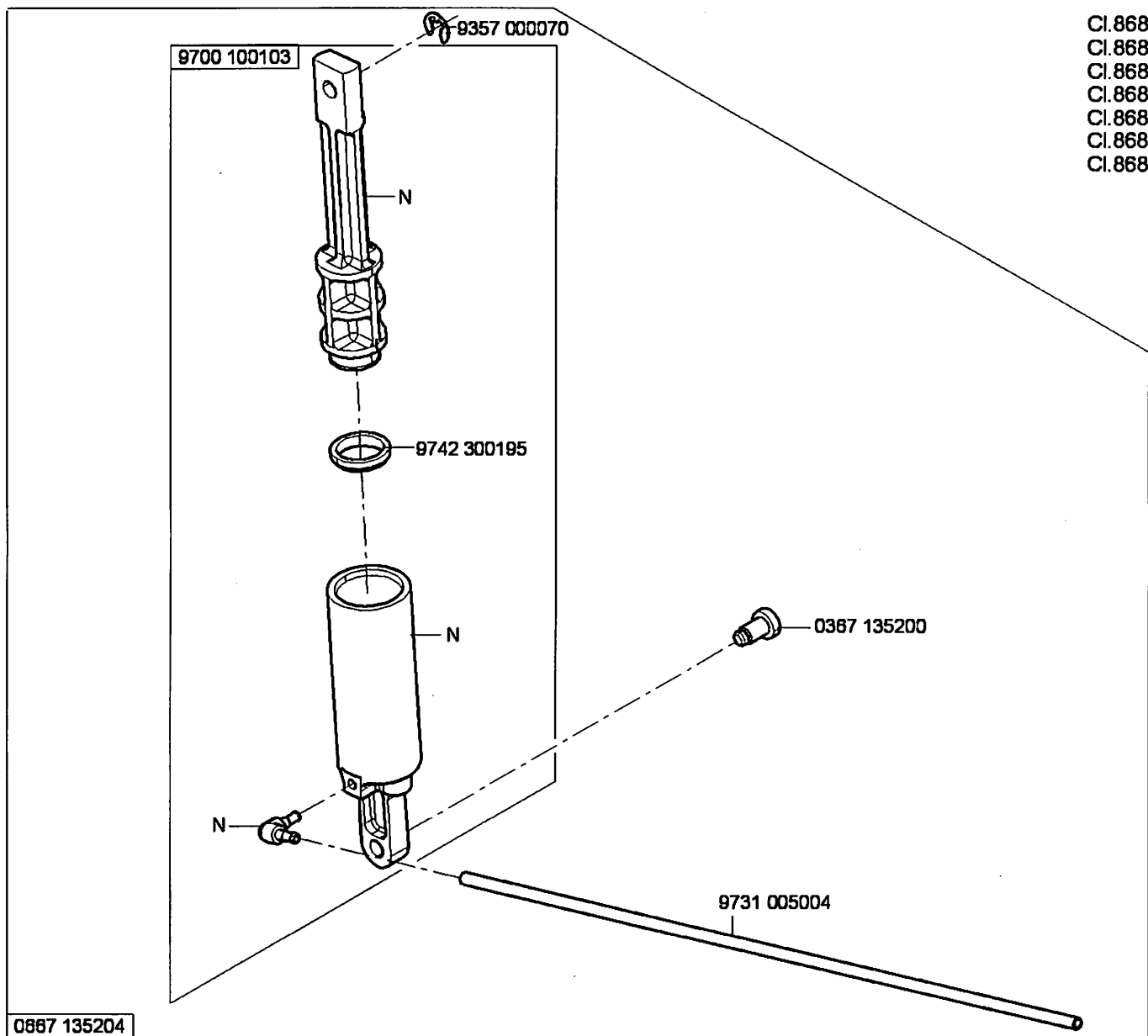

N - nicht als Einzelteil lieferbar  
not available as separate part

0887 135204

Cl. 868

Ausgabe/Edition 11.2009

Cl.868 -190322  
Cl.868 -190341  
Cl.868 -290321  
Cl.868 -290322  
Cl.868 -290341  
Cl.868 -390322  
Cl.868 -490322

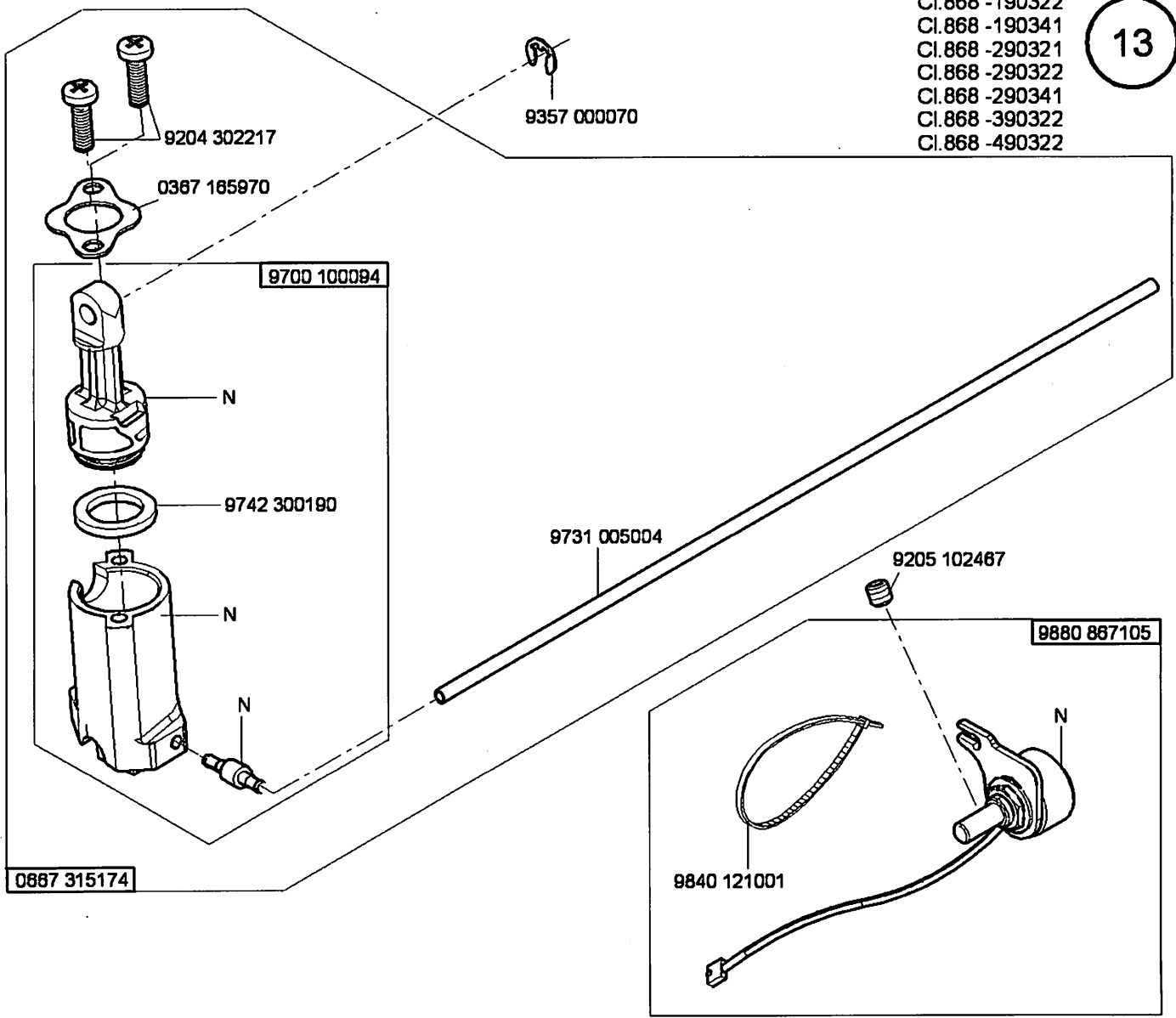
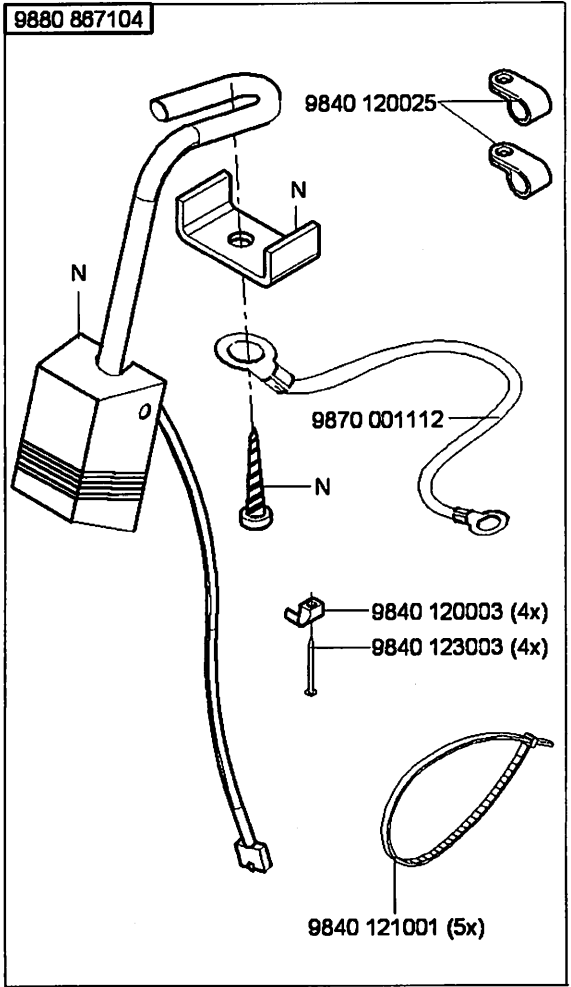

Cl. 868

Ausgabe/Edition 11.2009

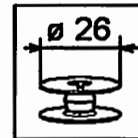

14

- Cl. 868 -190020
- Cl. 868 -190322
- Cl. 868 -290020
- Cl. 868 -290321
- Cl. 868 -290322
- Cl. 868 -390322
- Cl. 868 -490322

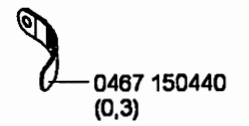
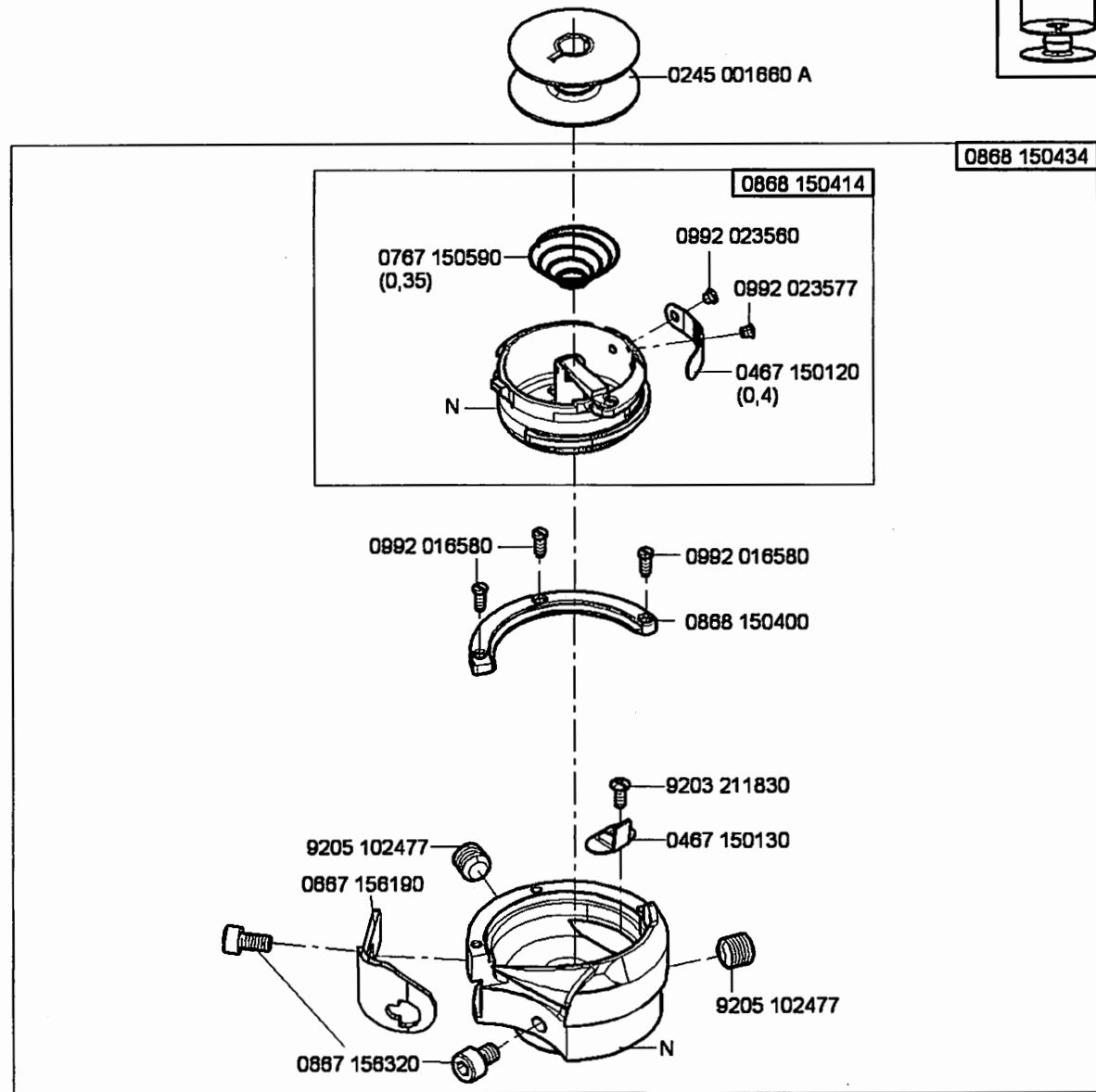

auf Wunsch  
on request

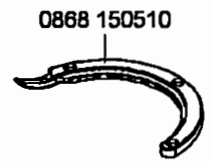

auf Wunsch  
on request

N - nicht als Einzelteil lieferbar  
not available as separate part

Cl. 868

Ausgabe/Edition 11.2009

auf Wunsch  
on request

0867 150870  
(0,45)

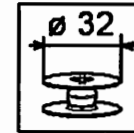

Cl.868 -190341  
Cl.868 -290341

15

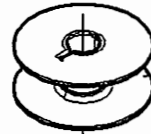

0867 150830

0868 150484

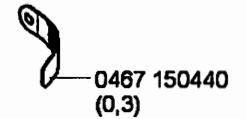
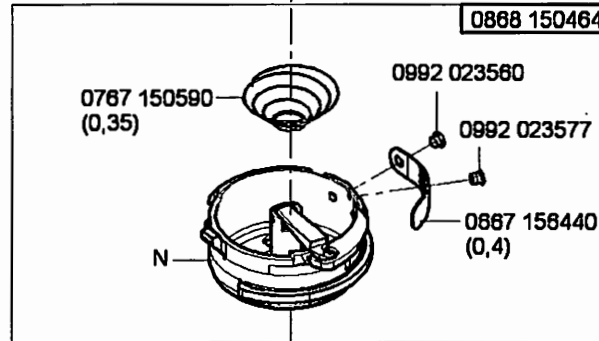

0467 150440  
(0,3)

auf Wunsch  
on request

0868 150520

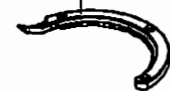

auf Wunsch  
on request

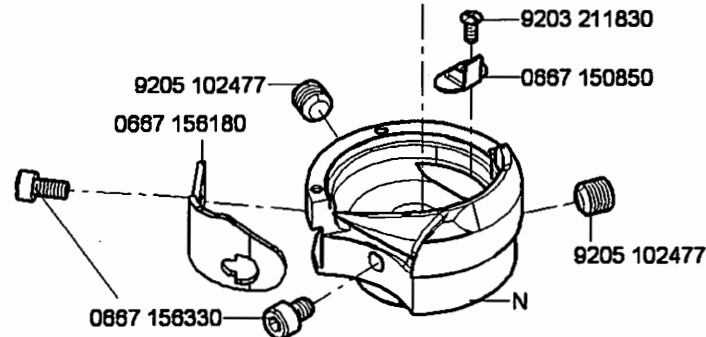
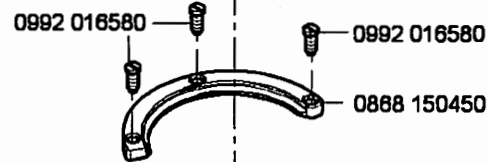

N - nicht als Einzelteil lieferbar  
not available as separate part

Cl. 868

Ausgabe/Edition 11.2008

CI.868 -190020  
 CI.868 -190322  
 CI.868 -190341  
 CI.868 -290020  
 CI.868 -290321  
 CI.868 -290322  
 CI.868 -290341  
 CI.868 -490322

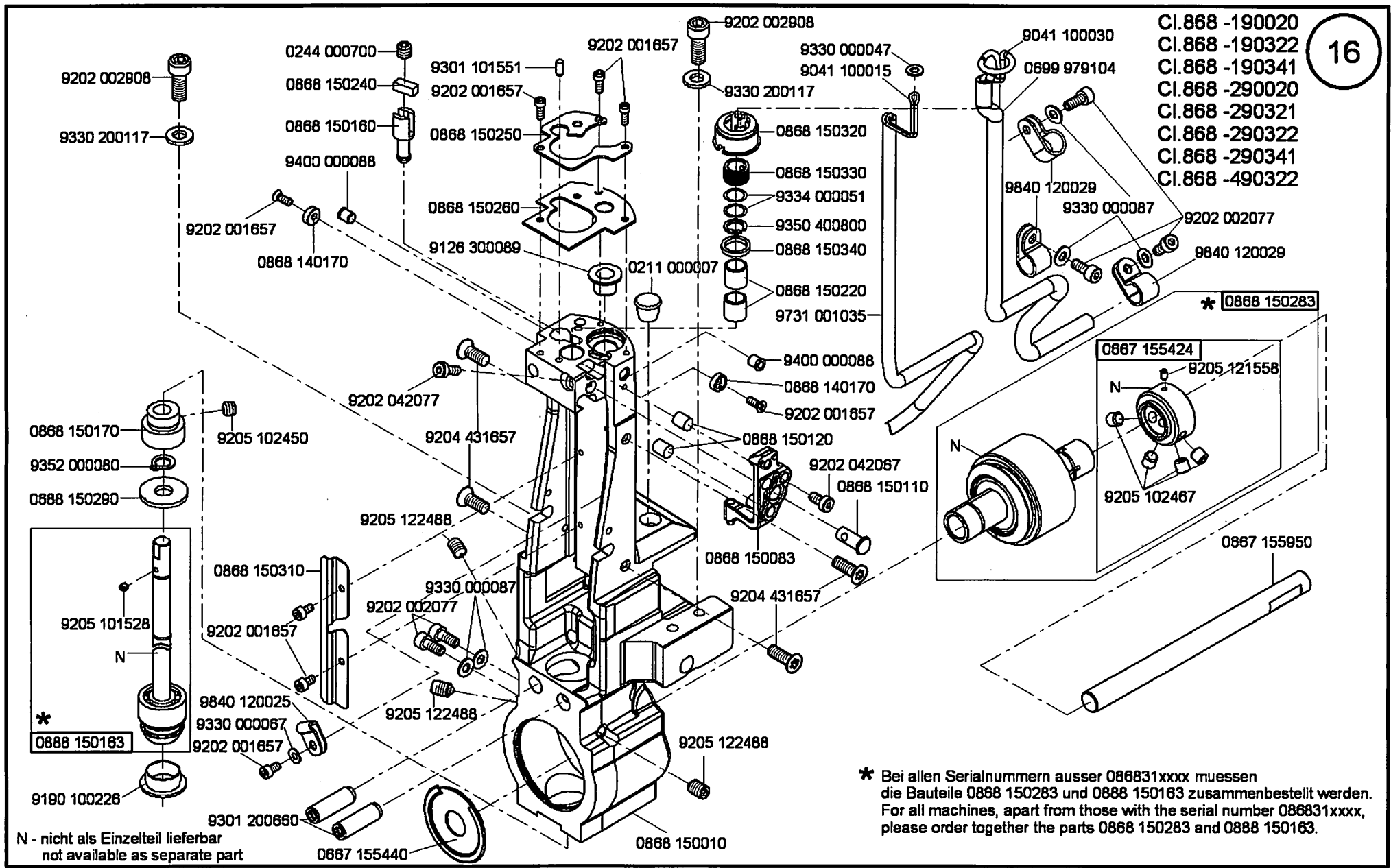

\* 0888 150163

0867 155424  
 9205 121558  
 N  
 9205 102467  
 0867 155950

N - nicht als Einzelteil lieferbar  
 not available as separate part

\* Bei allen Seriennummern ausser 086831xxxx muessen die Bauteile 0868 150283 und 0888 150163 zusammenbestellt werden.  
 For all machines, apart from those with the serial number 086831xxxx, please order together the parts 0868 150283 and 0888 150163.

CI.868

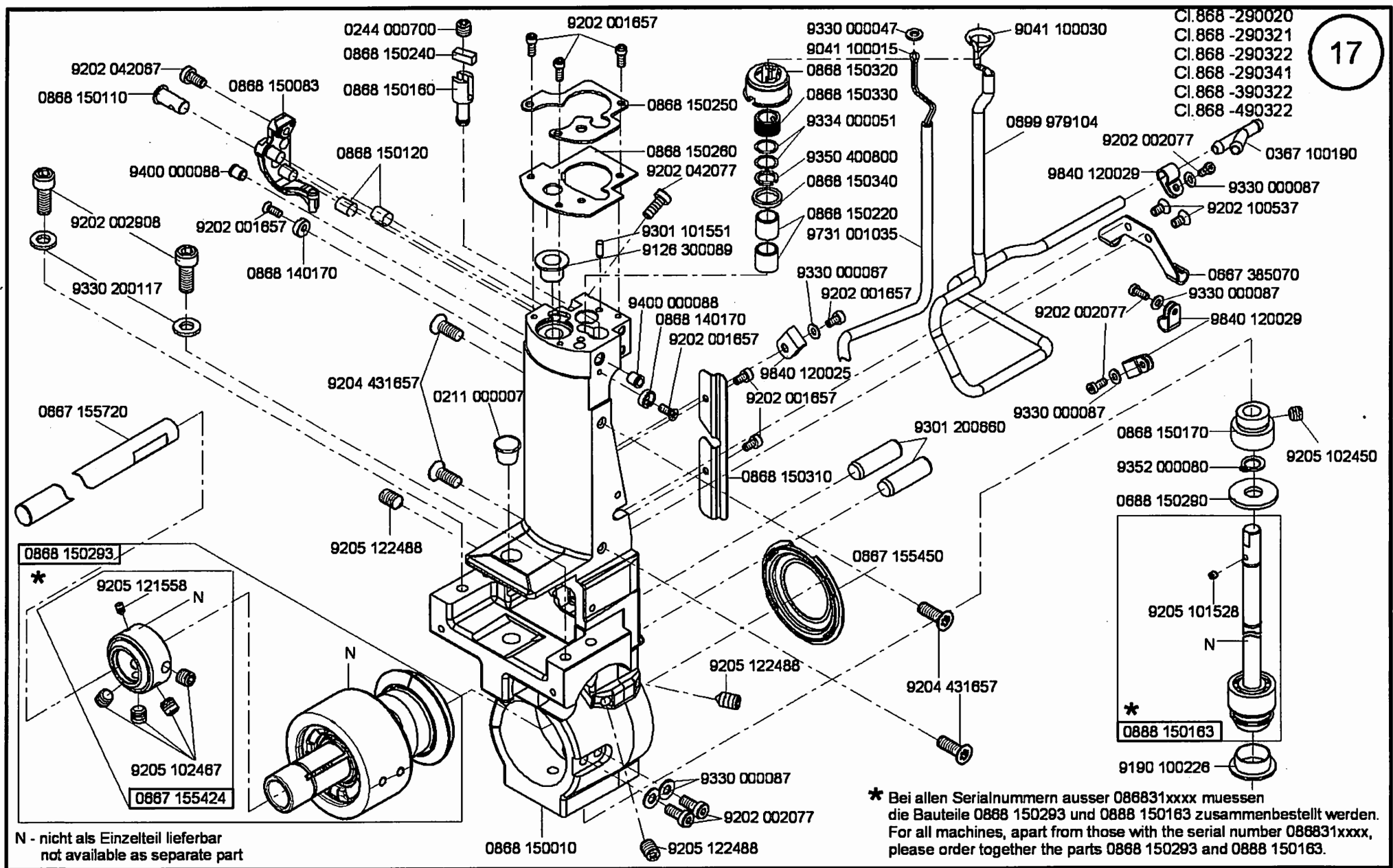

CI. 868

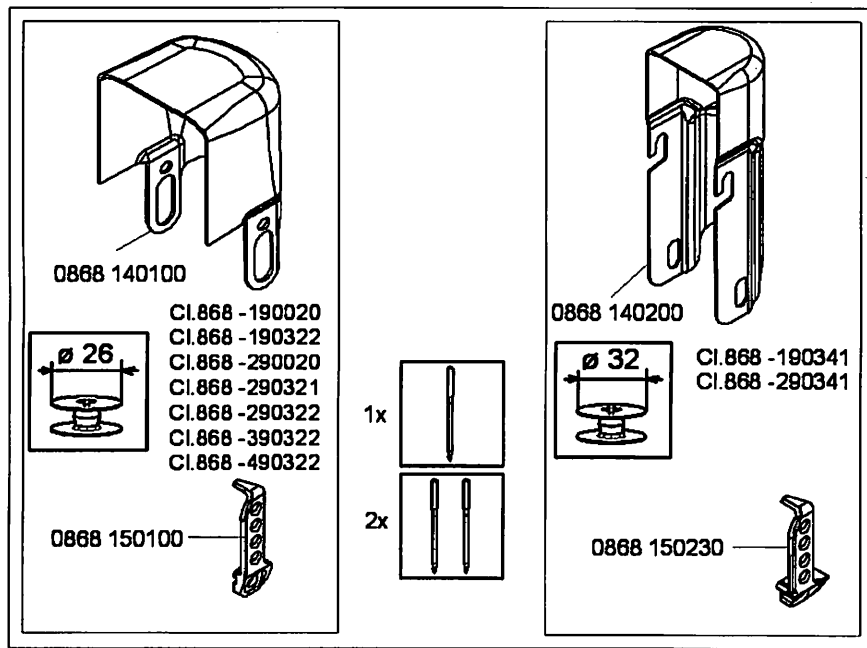

N - nicht als Einzelteil lieferbar  
not available as separate part

CI.868

Ausgabe/Edition 12.2009



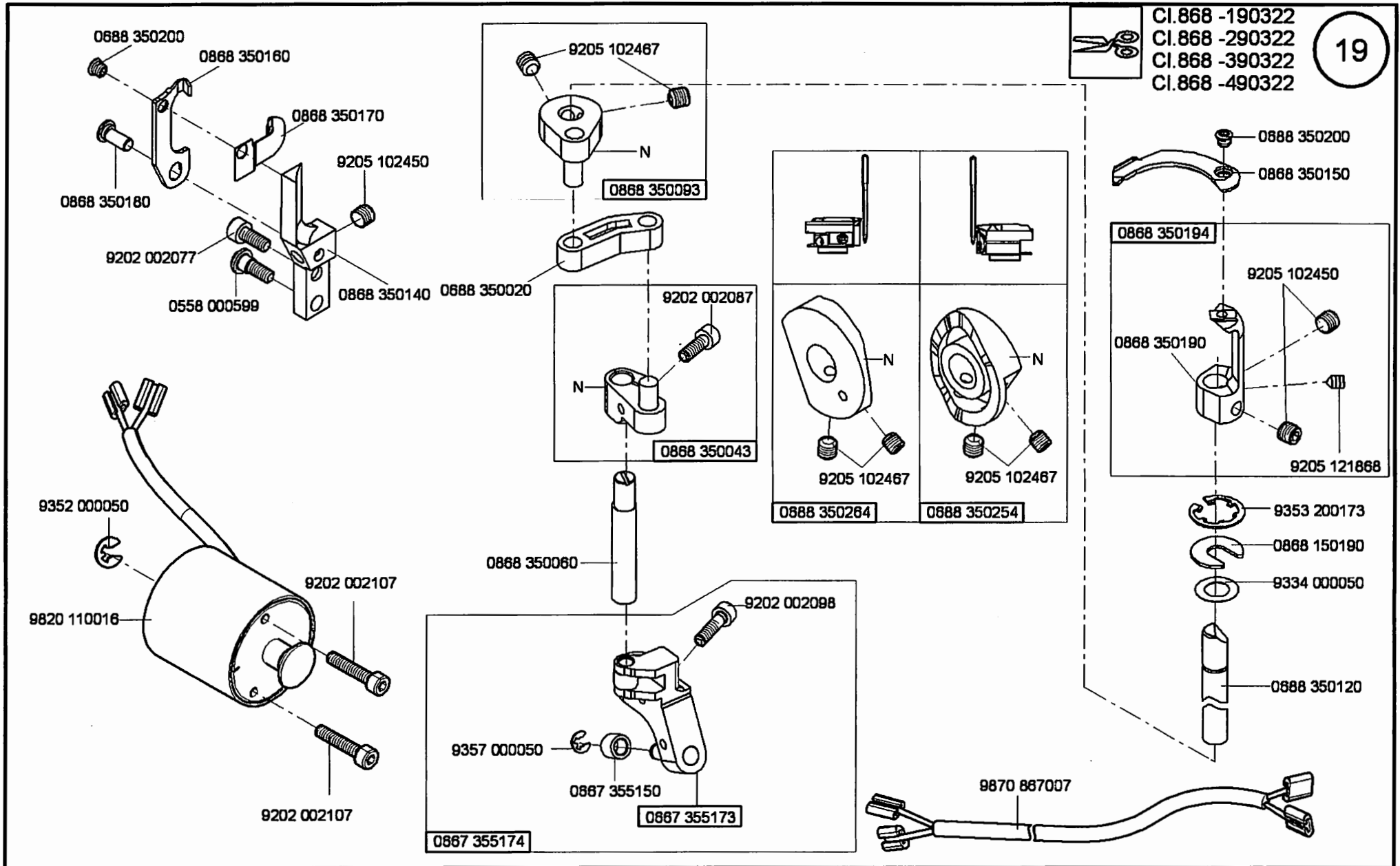

CI. 868

Ausgabe/Edition 11.2009



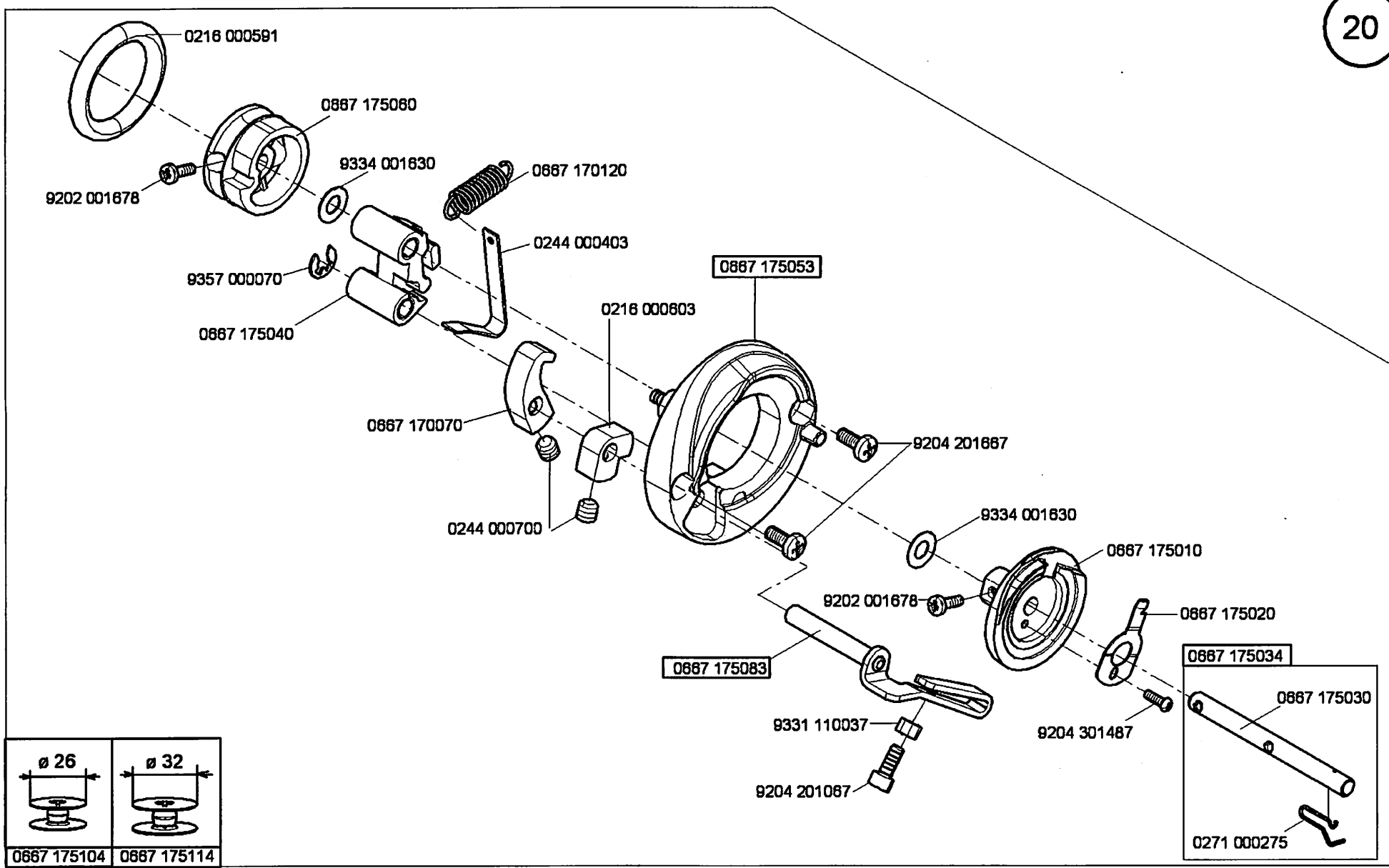

Cl. 868

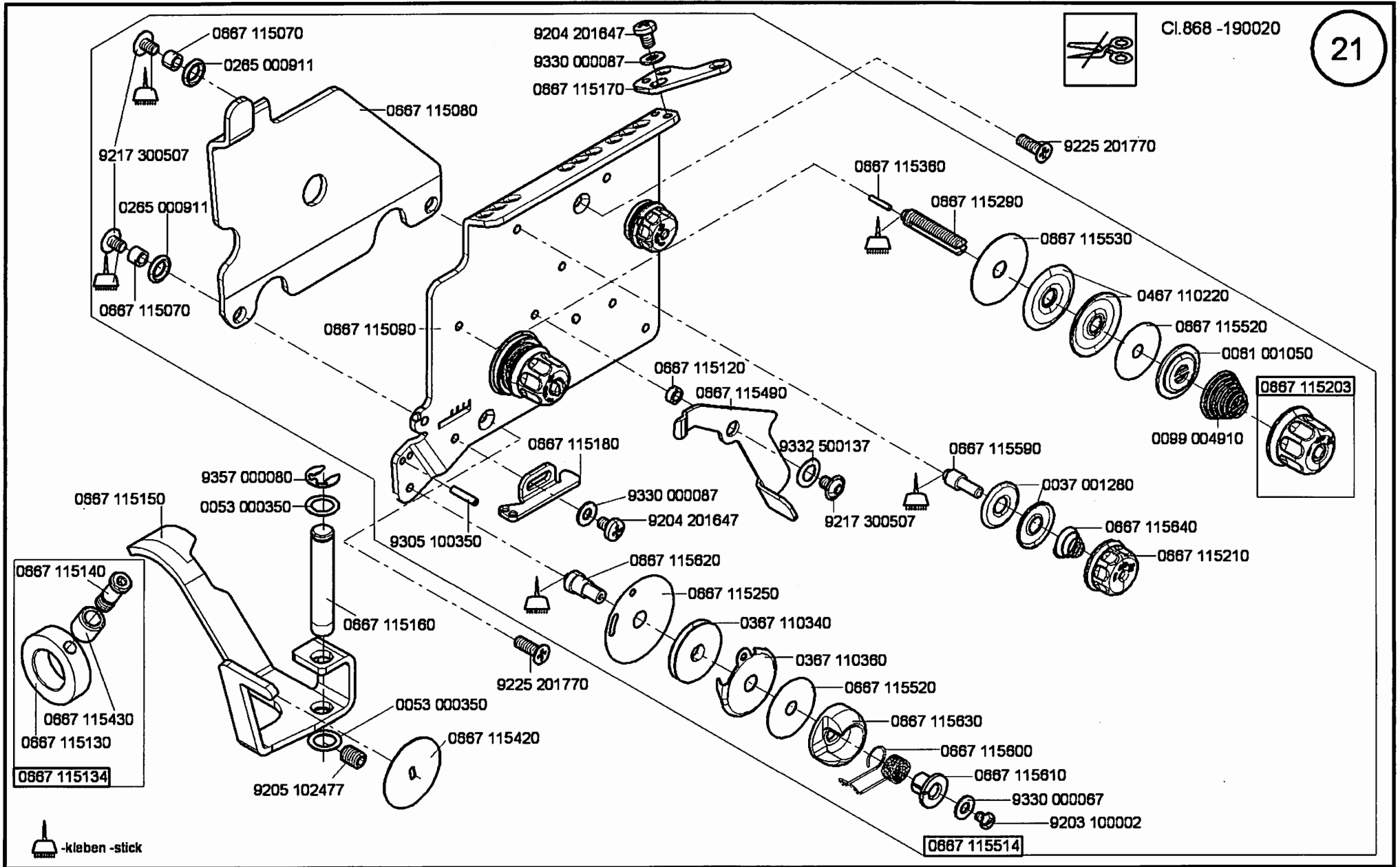

Cl. 868

Ausgabe/Edition 11.2008

Cl.868 -190322  
Cl.868 -190341  
Cl.868 -390322

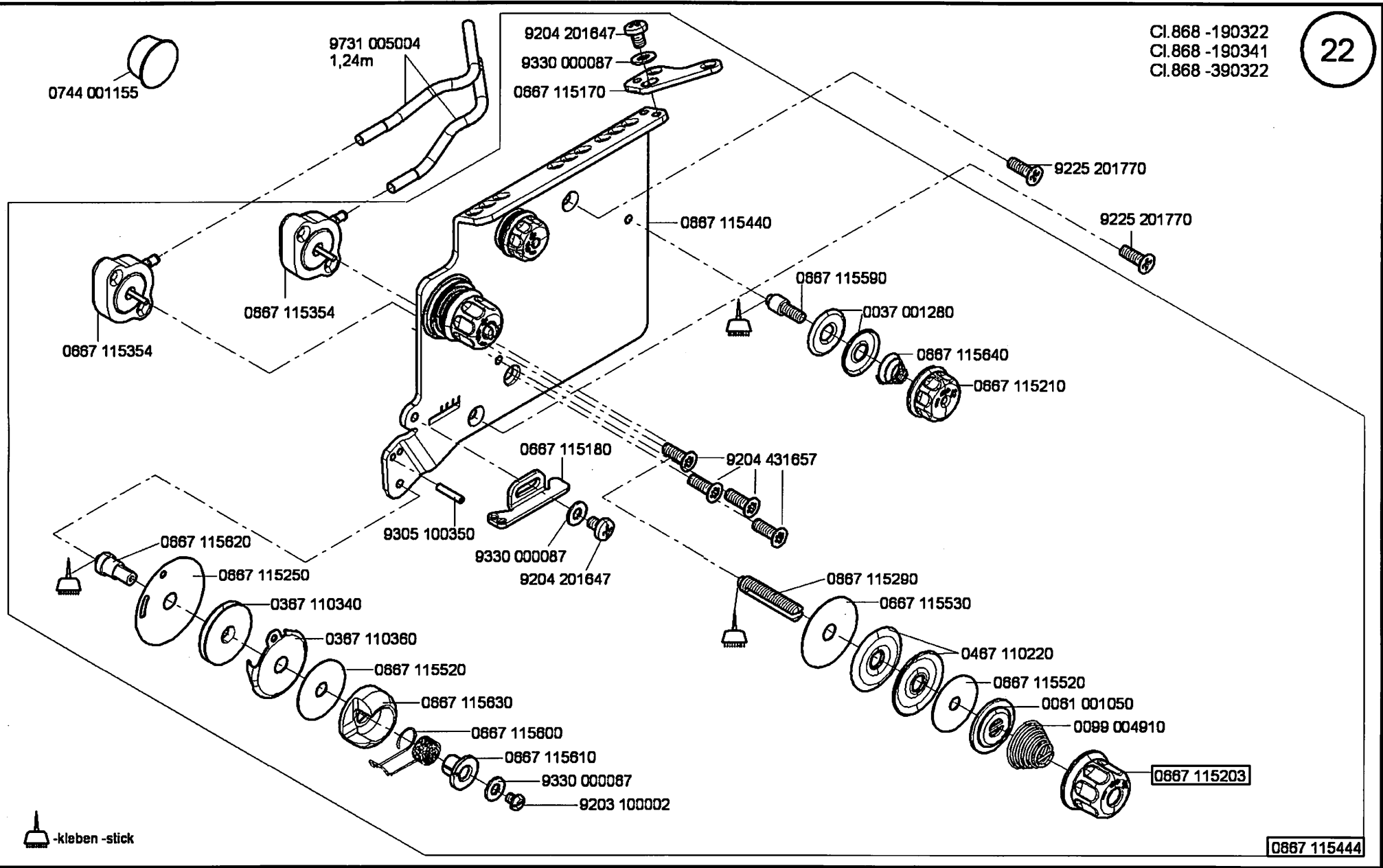

-kleben -stick

0867 115444

Cl. 868

Ausgabe/Edition 11.2008



Cl.868 -290020

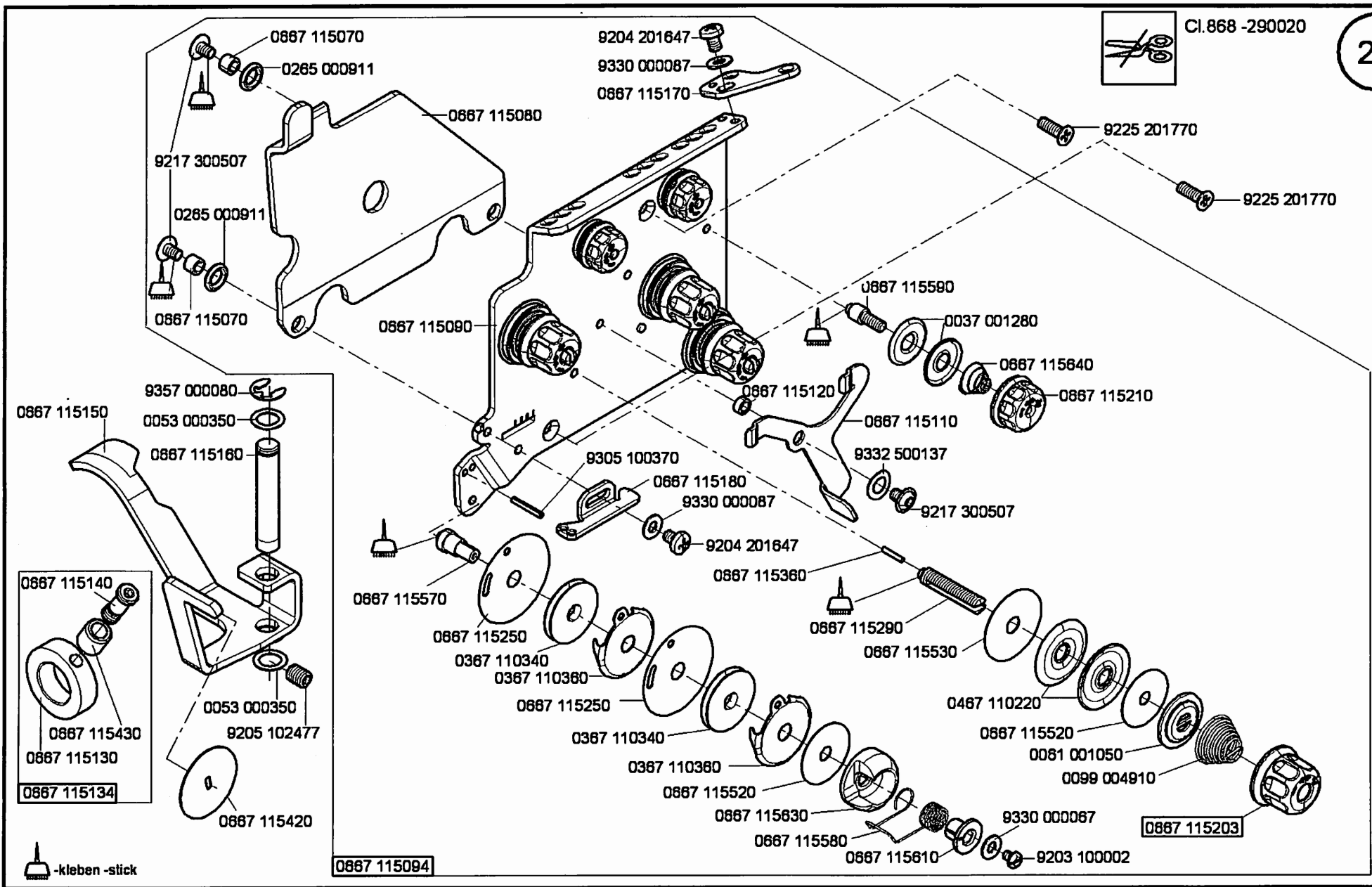

-kleben -stick

Cl. 868

Ausgabe/Edition 11.2008

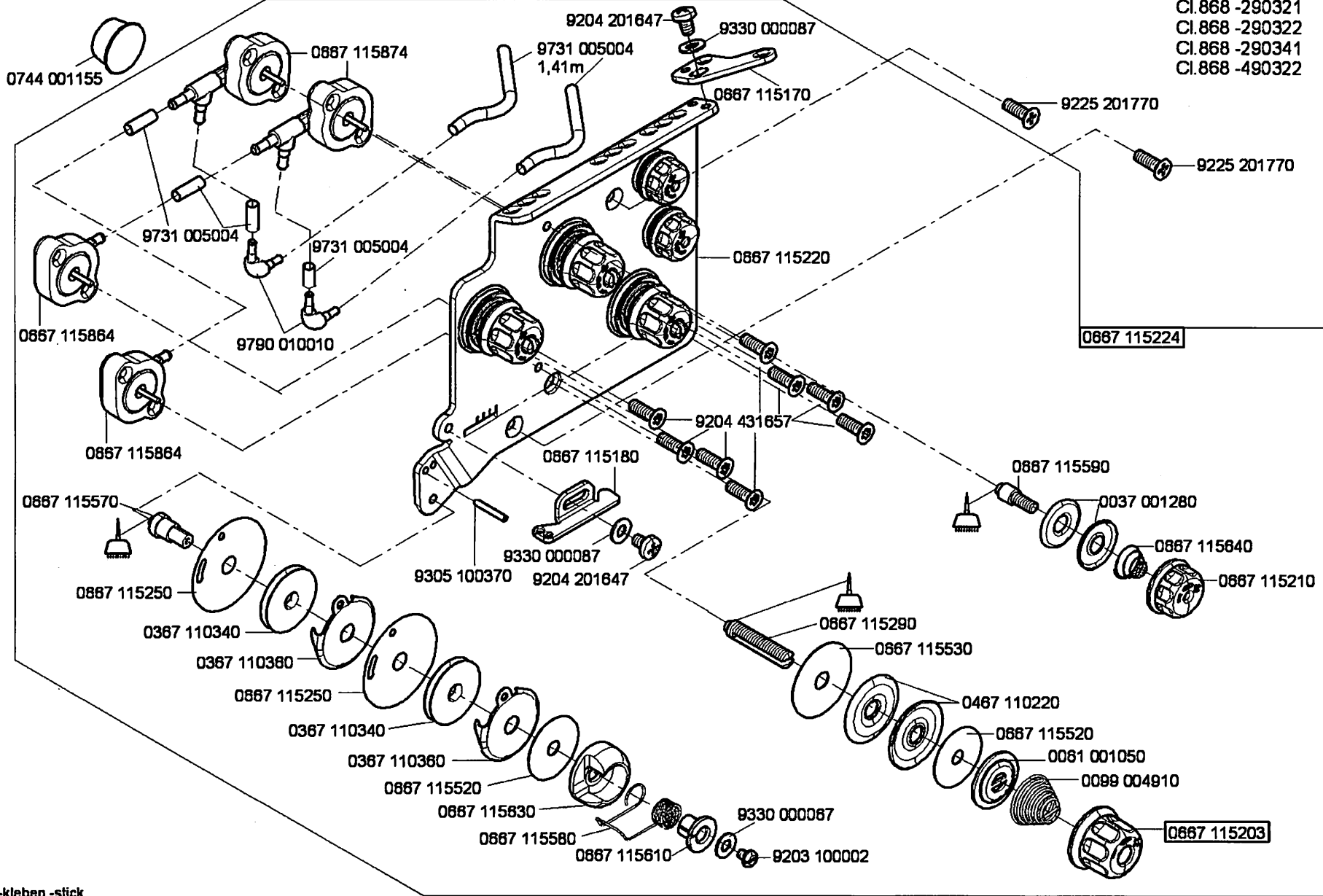

-kleben -stick

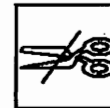

Cl.868 -190020  
Cl.868 -290020

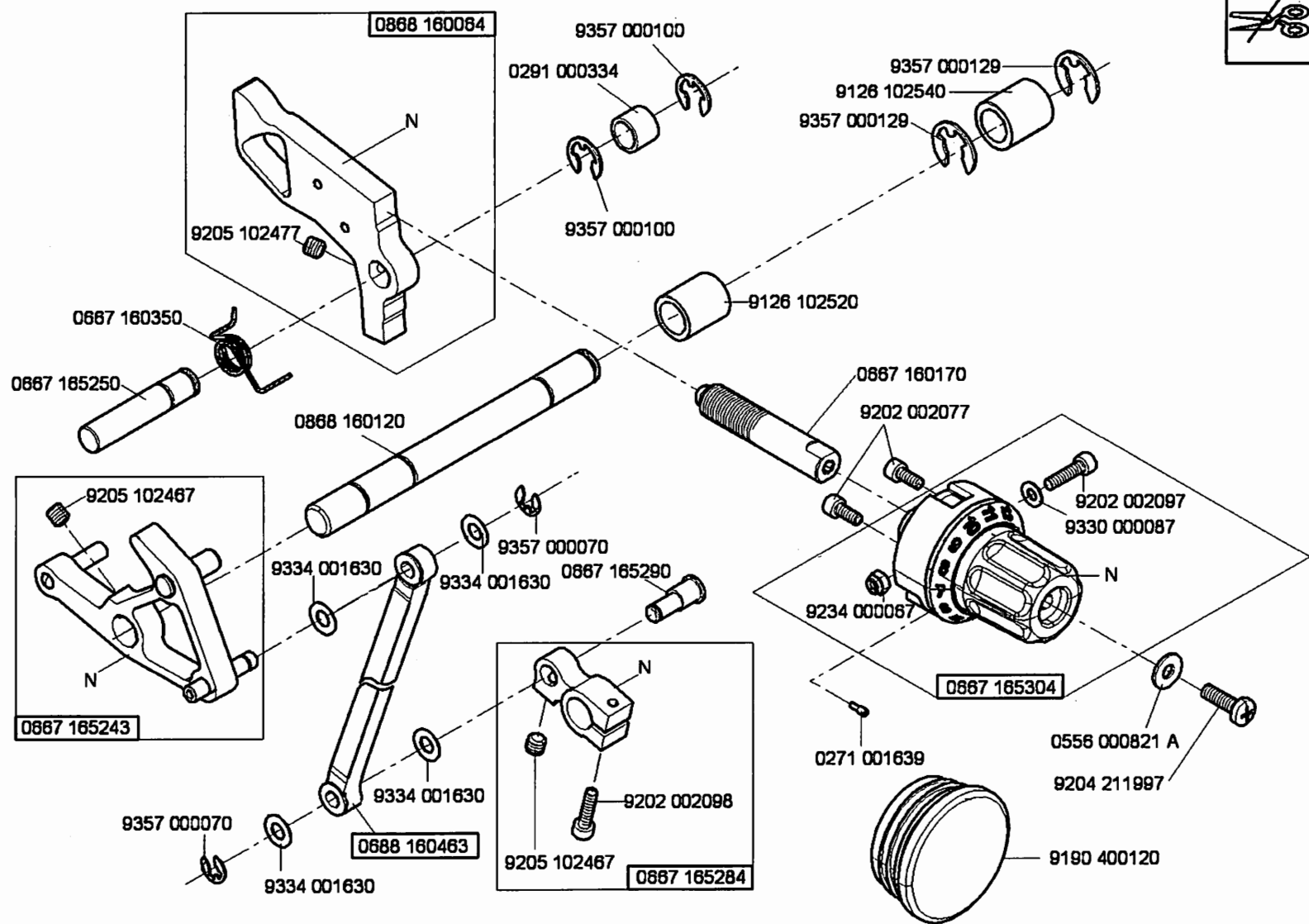

N - nicht als Einzelteil lieferbar  
not available as separate part

Cl. 868



Cl.868 -190322  
Cl.868 -190341  
Cl.868 -290321  
Cl.868 -290322  
Cl.868 -290341  
Cl.868 -390322  
Cl.868 -490322

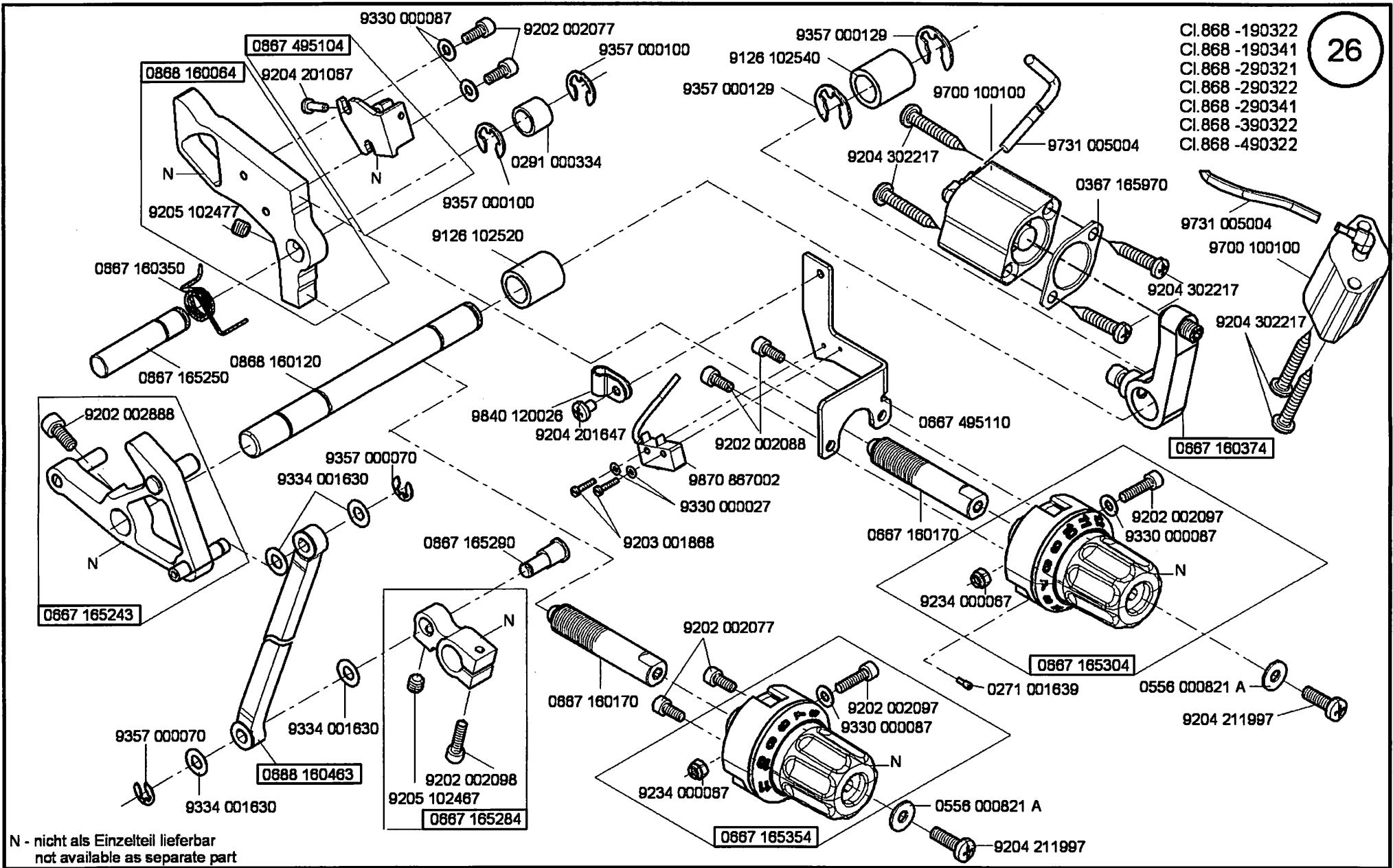

N - nicht als Einzelteil lieferbar  
not available as separate part

Cl. 868

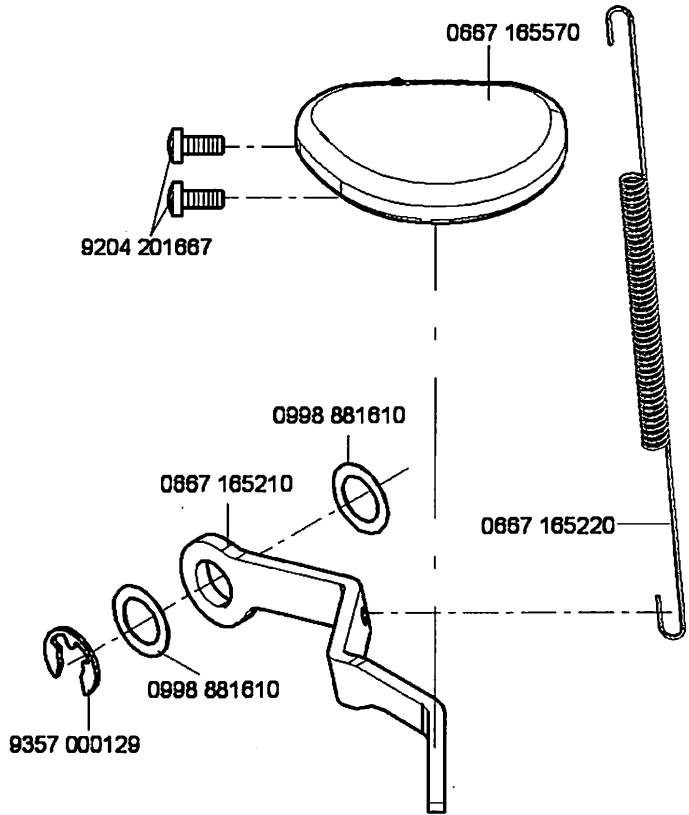

- 0667 165464
- Cl.868 -190322
  - Cl.868 -190341
  - Cl.868 -290321
  - Cl.868 -290322
  - Cl.868 -290341
  - Cl.868 -390322
  - Cl.868 -490322

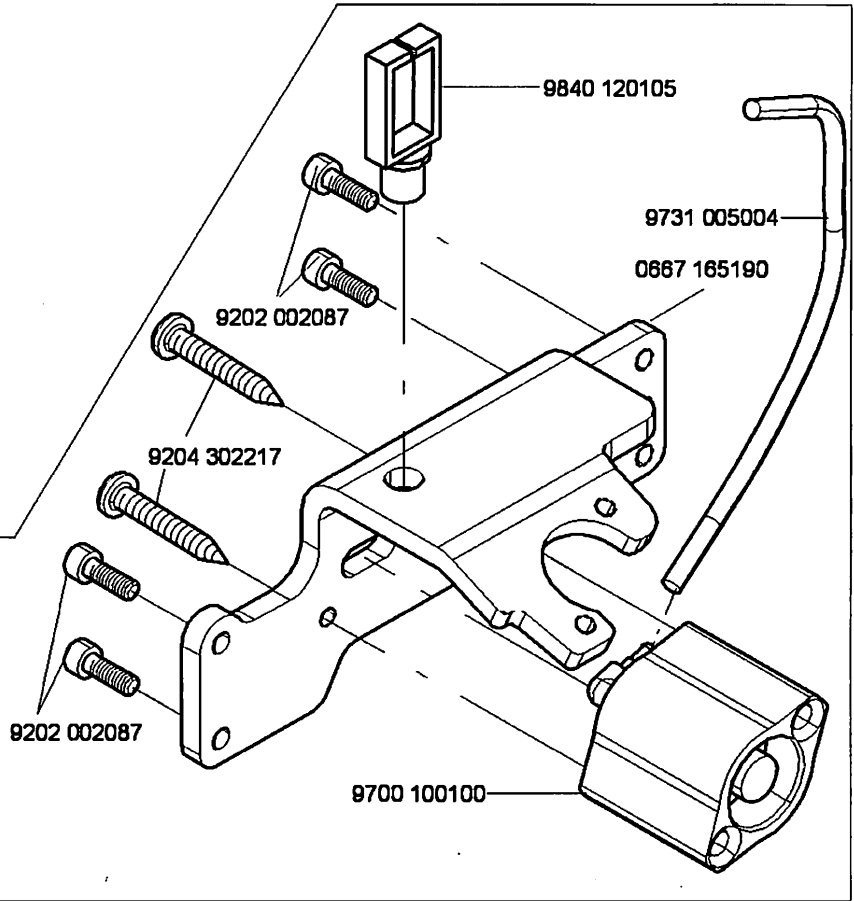



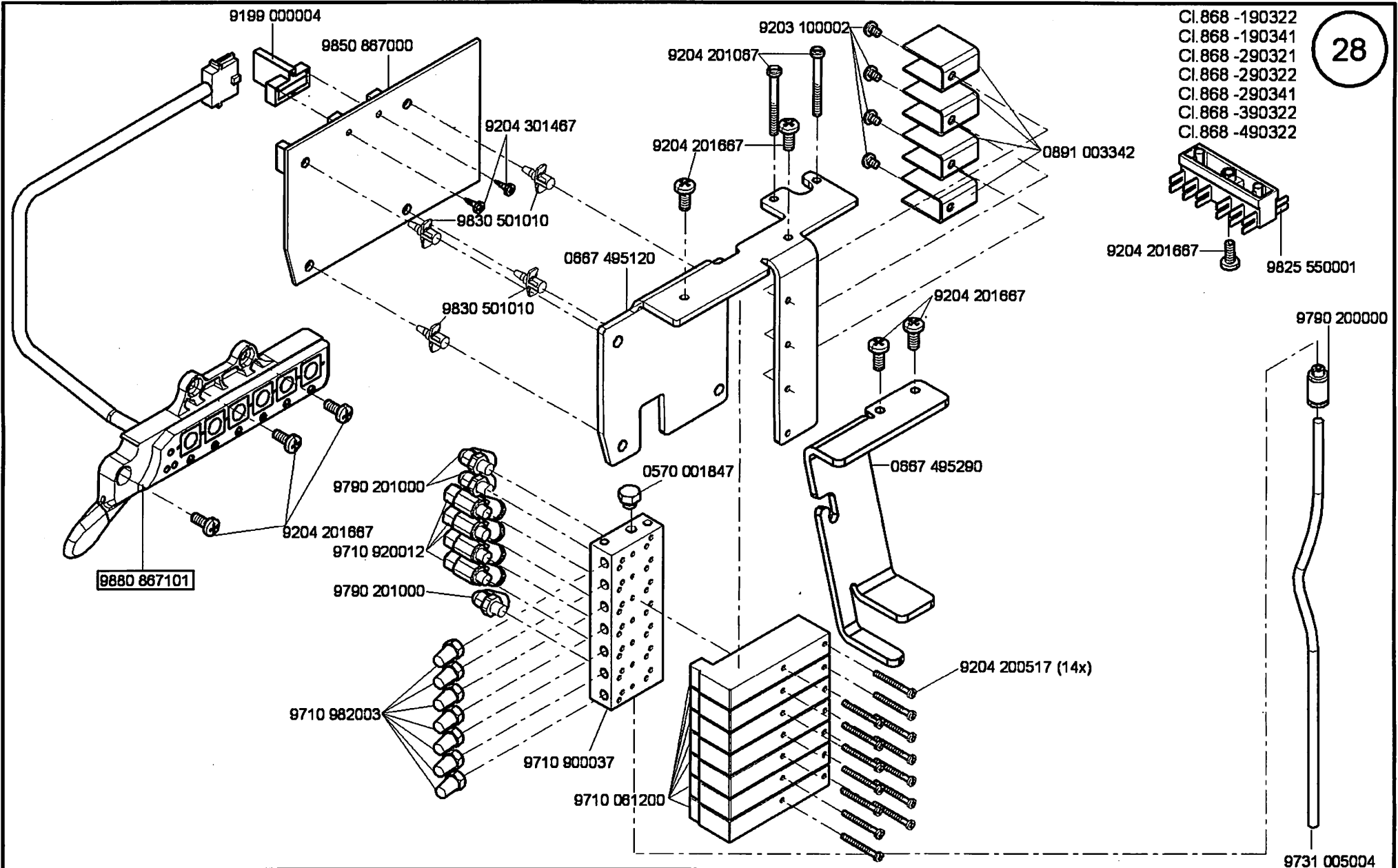

- Cl. 868 -190322
- Cl. 868 -190341
- Cl. 868 -290321
- Cl. 868 -290322
- Cl. 868 -290341
- Cl. 868 -390322
- Cl. 868 -490322

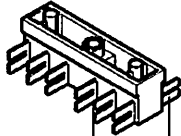

9204 201667 9825 550001

Cl. 868

Ausgabe/Edition 1.2010

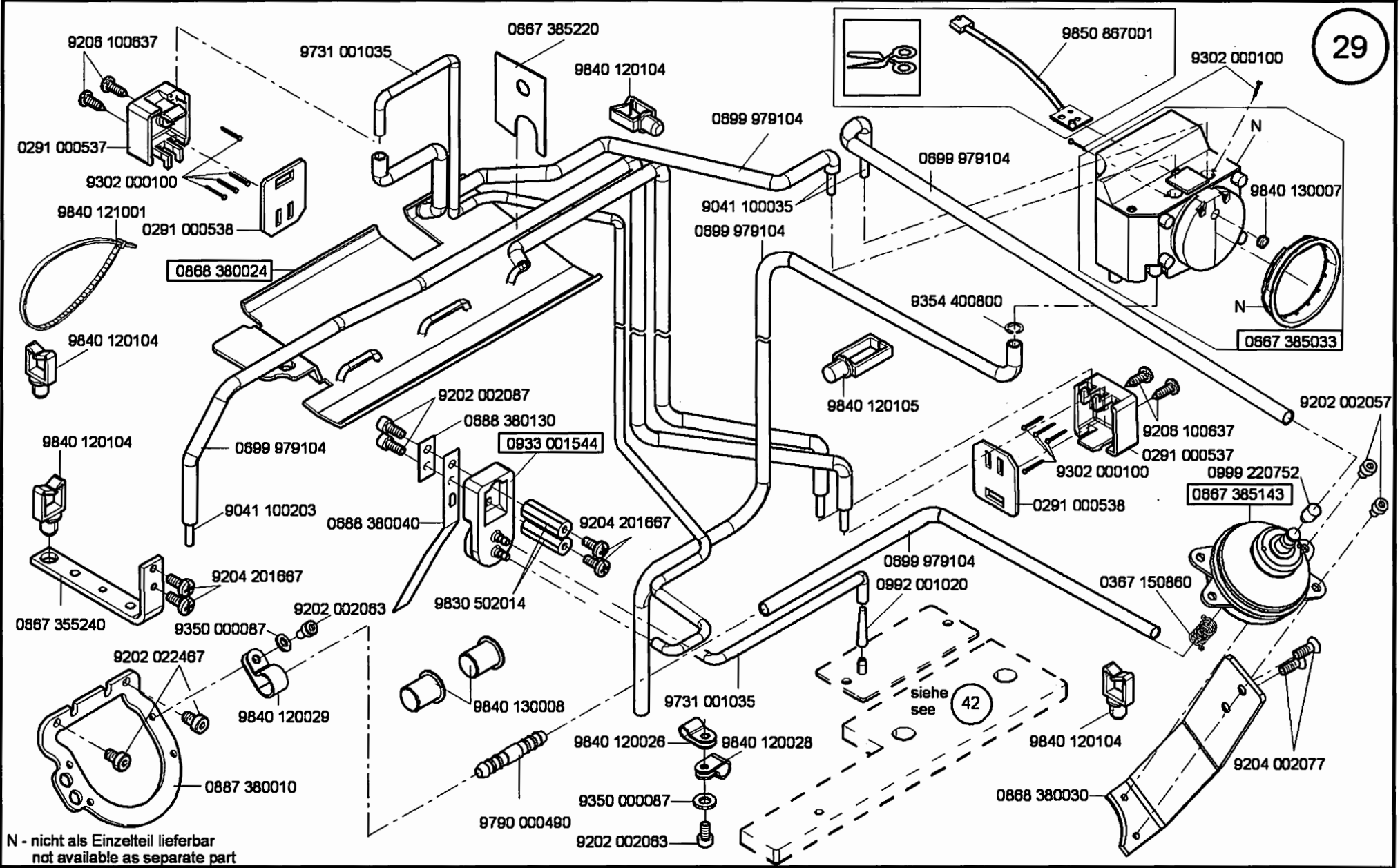

N - nicht als Einzelteil lieferbar  
not available as separate part

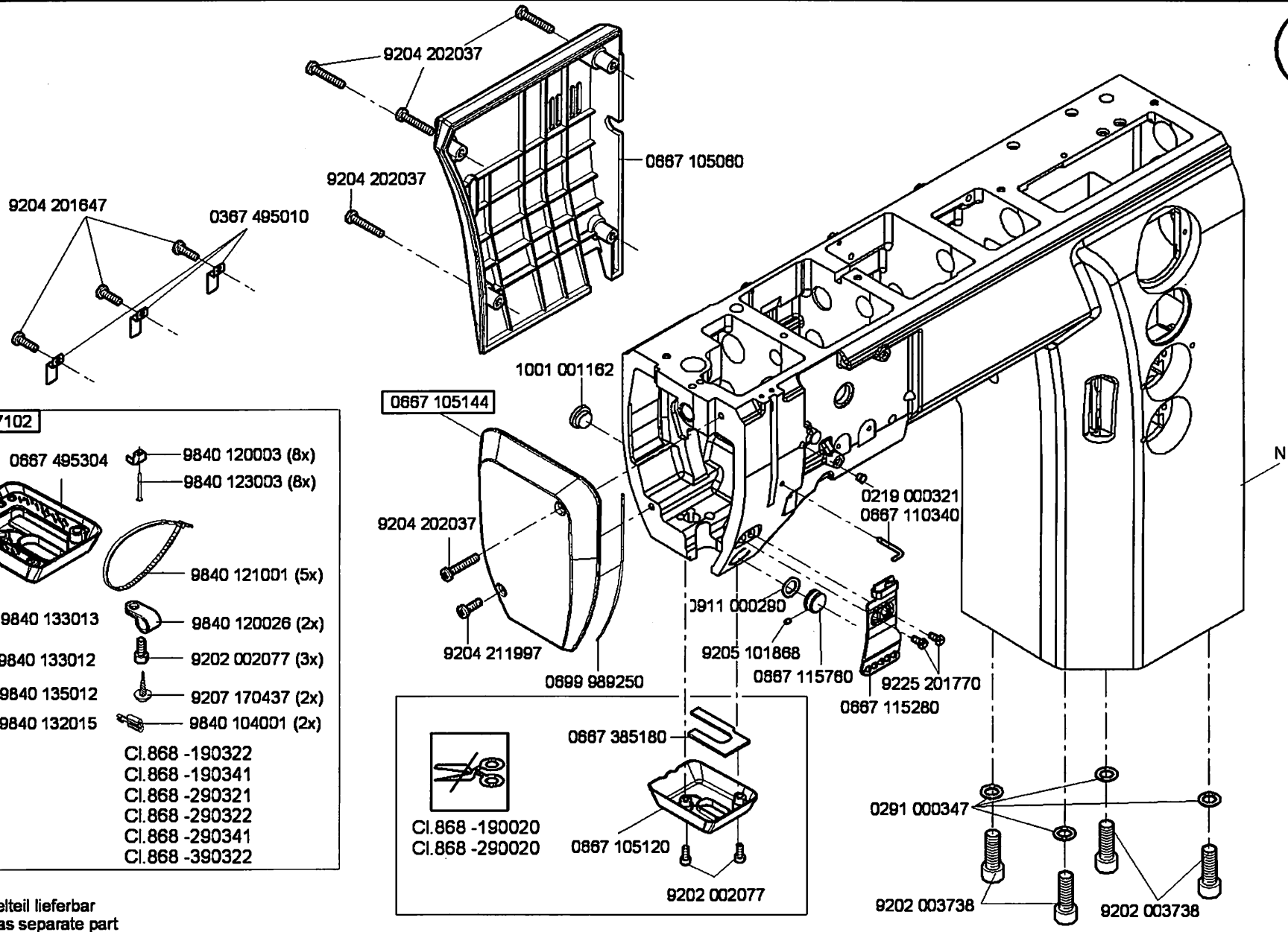

9880 887102

- 0867 495304
- 9840 120003 (8x)
- 9840 123003 (8x)
- 9840 121001 (5x)
- 9840 133013
- 9840 120026 (2x)
- 9840 133012
- 9202 002077 (3x)
- 9840 135012
- 9207 170437 (2x)
- 9840 132015
- 9840 104001 (2x)

- Cl.868 -190322
- Cl.868 -190341
- Cl.868 -290321
- Cl.868 -290322
- Cl.868 -290341
- Cl.868 -390322

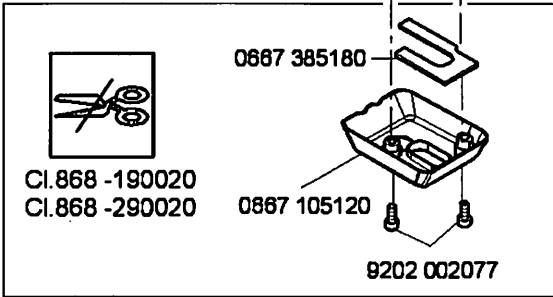

N - nicht als Einzelteil lieferbar  
not available as separate part

Cl. 868

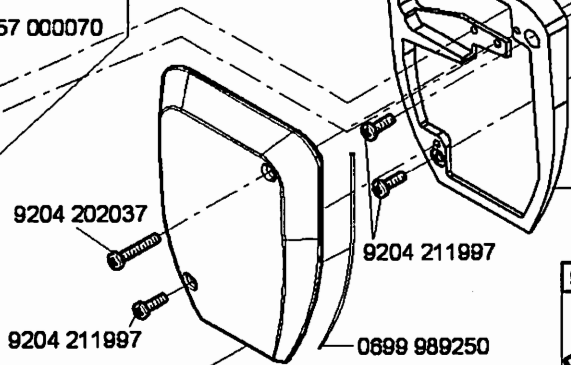
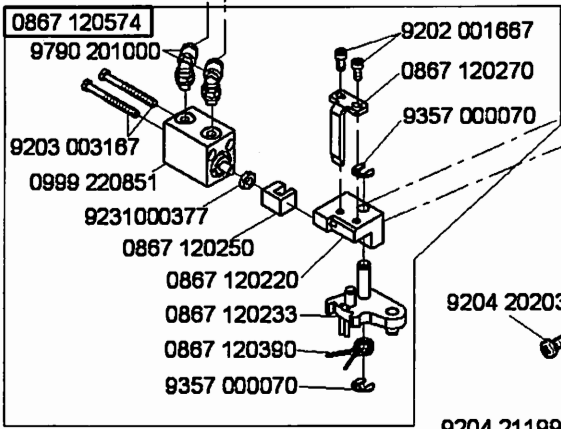
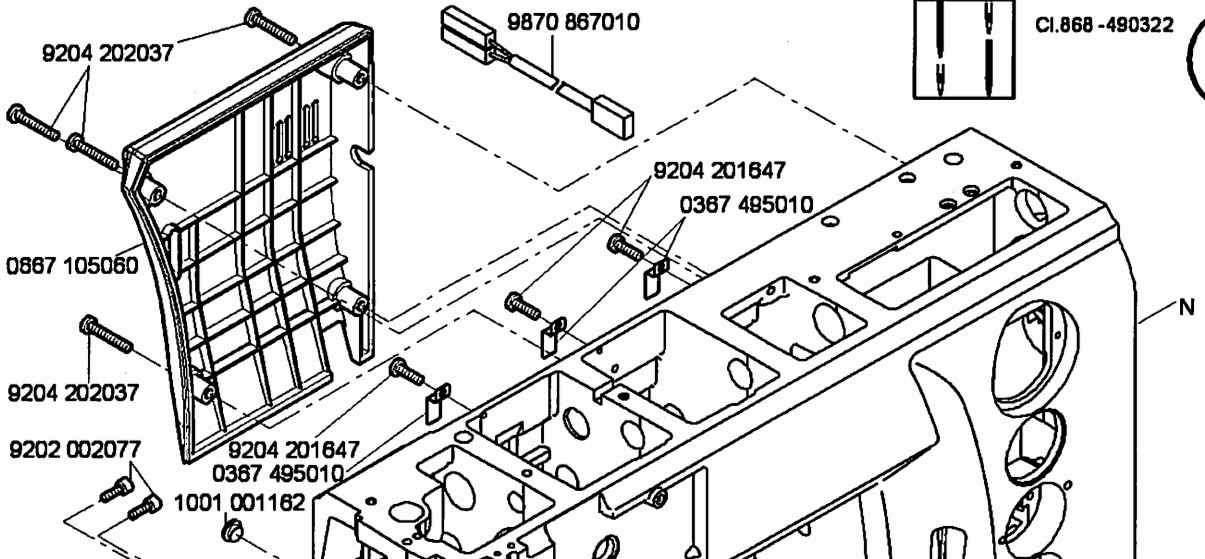
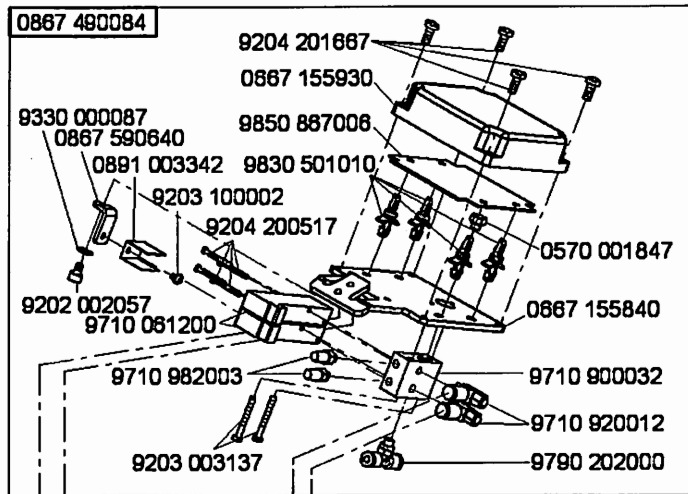

- 9880 867114
- 0867 120584
- 9840 120003 (8x)
- 9840 123003 (8x)
- 9840 121001 (5x)
- 9840 133013
- 9840 133012
- 9840 135012
- 9840 132015
- 9840 120026 (2x)
- 9202 002077 (3x)
- 9207 170437 (2x)
- 9840 104001 (2x)

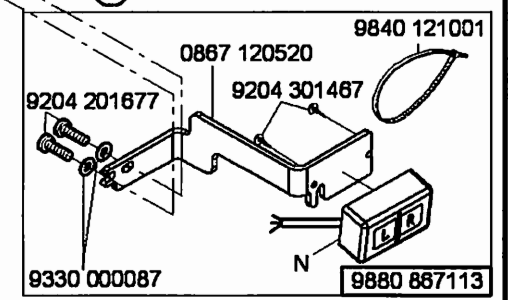

N - nicht als Einzelteil lieferbar  
not available as separate part



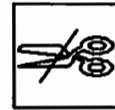

CI.868 -190020  
CI.868 -290020

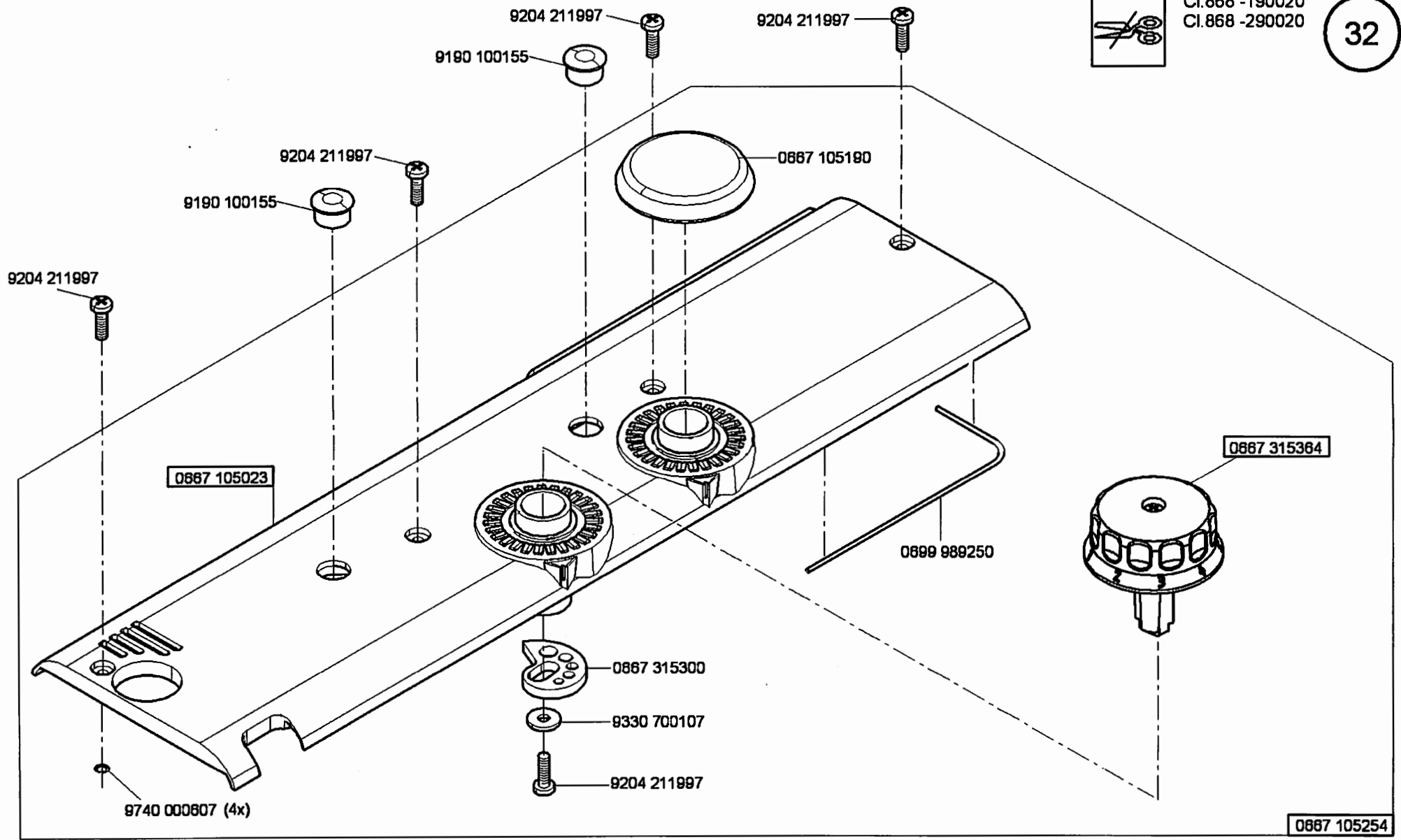

CI. 868

Ausgabe/Edition 11.2008

- Cl.868 -190322
- Cl.868 -190341
- Cl.868 -290321
- Cl.868 -290322
- Cl.868 -290341
- Cl.868 -390322
- Cl.869 -490322

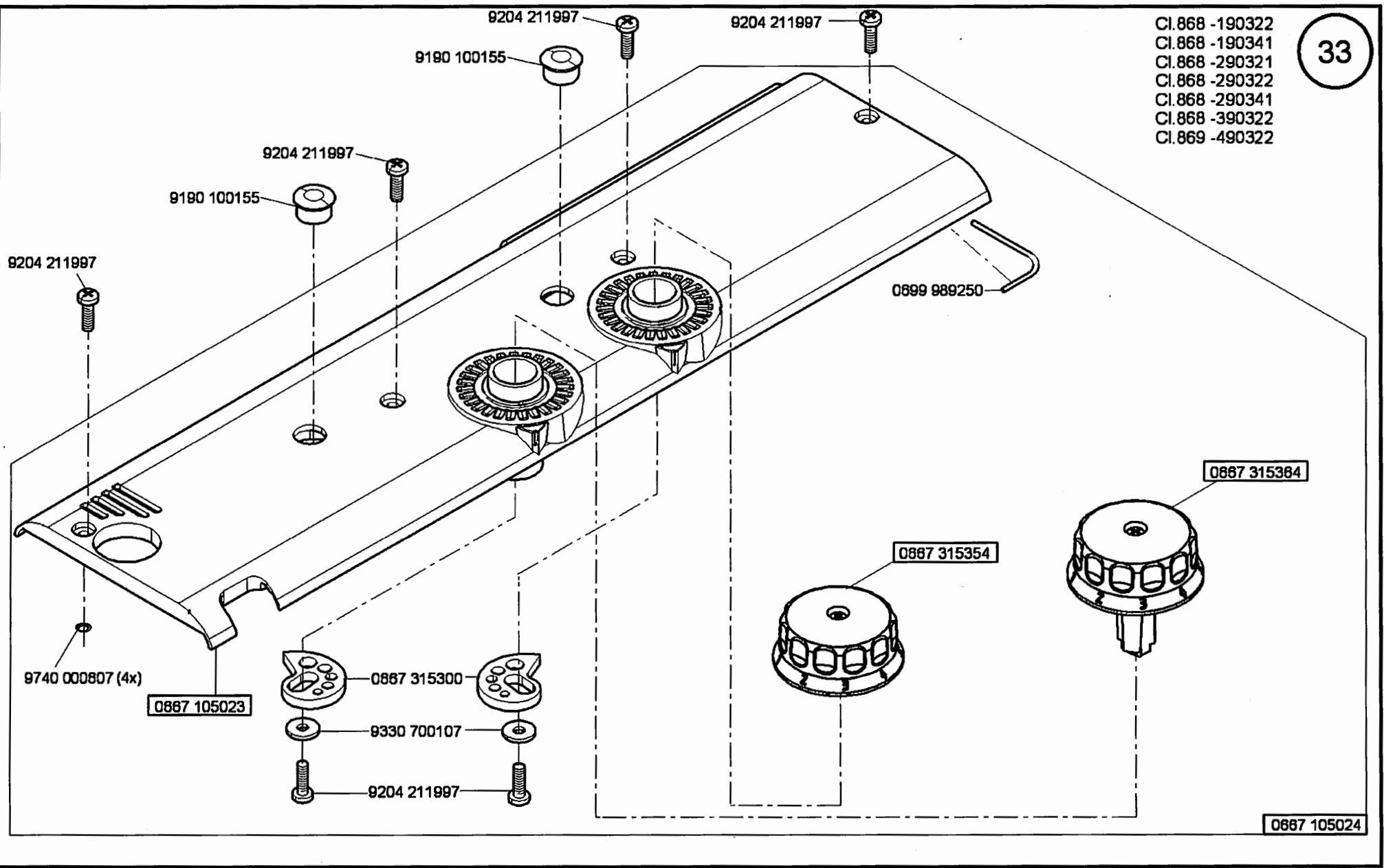

Cl. 868

Ausgabe/Edition 11.2009

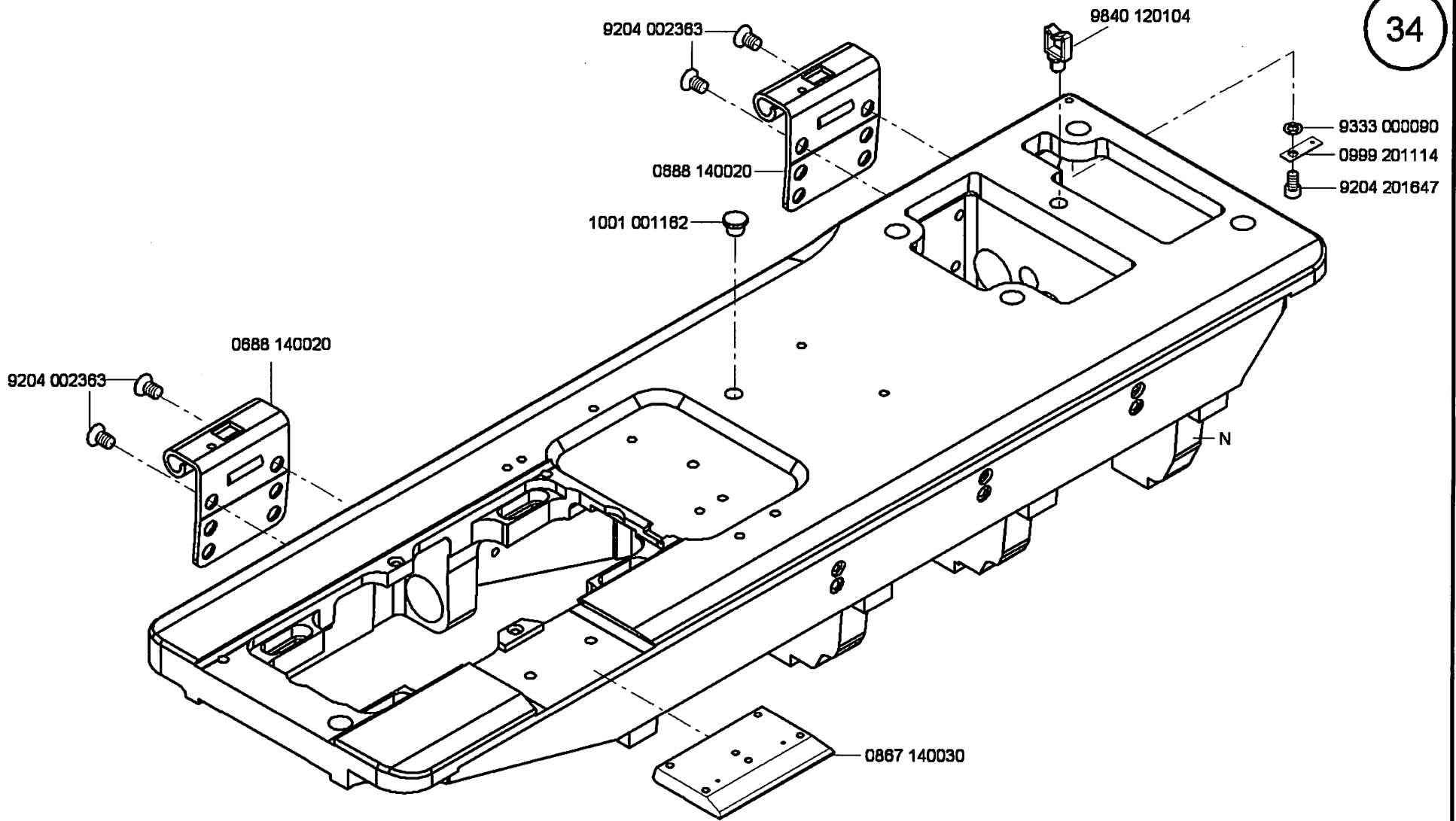

N - nicht als Einzelteil lieferbar  
not available as separate part

Cl. 868

Ausgabe/Edition 8.2008

9822 510003

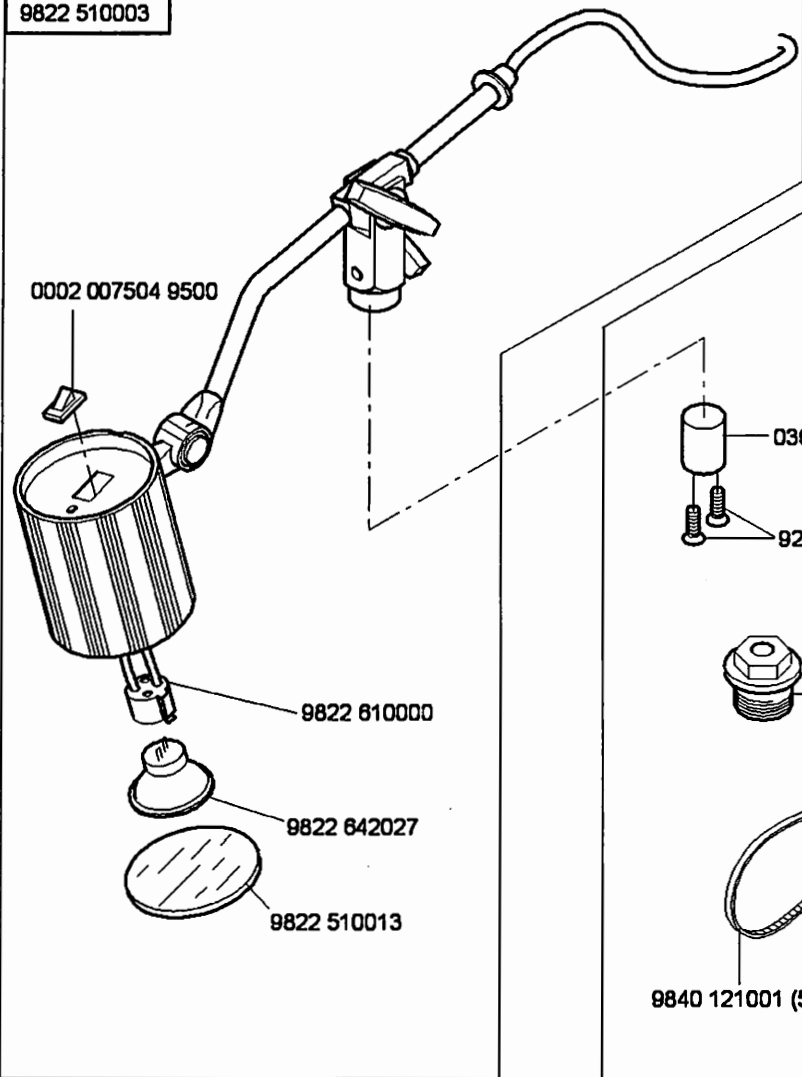

9880 867100

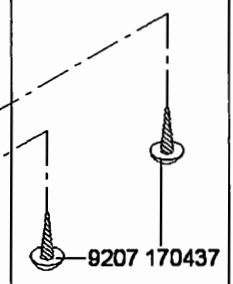
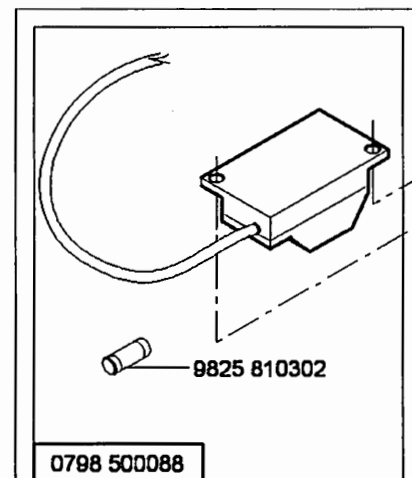
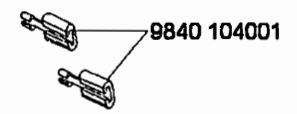
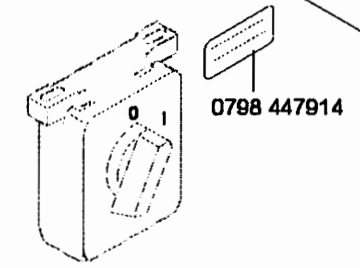
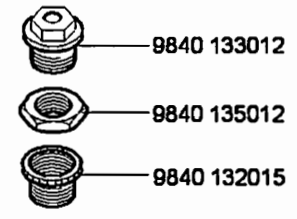
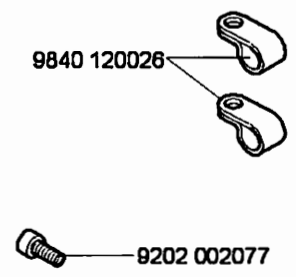
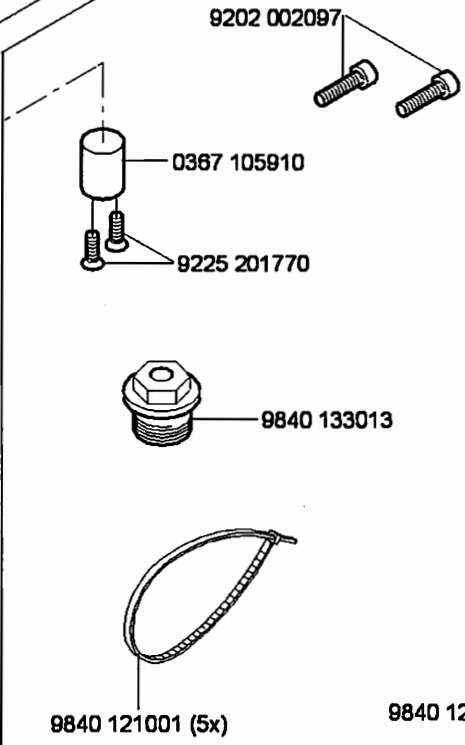

Cl. 868

Ausgabe/Edition 8.2008



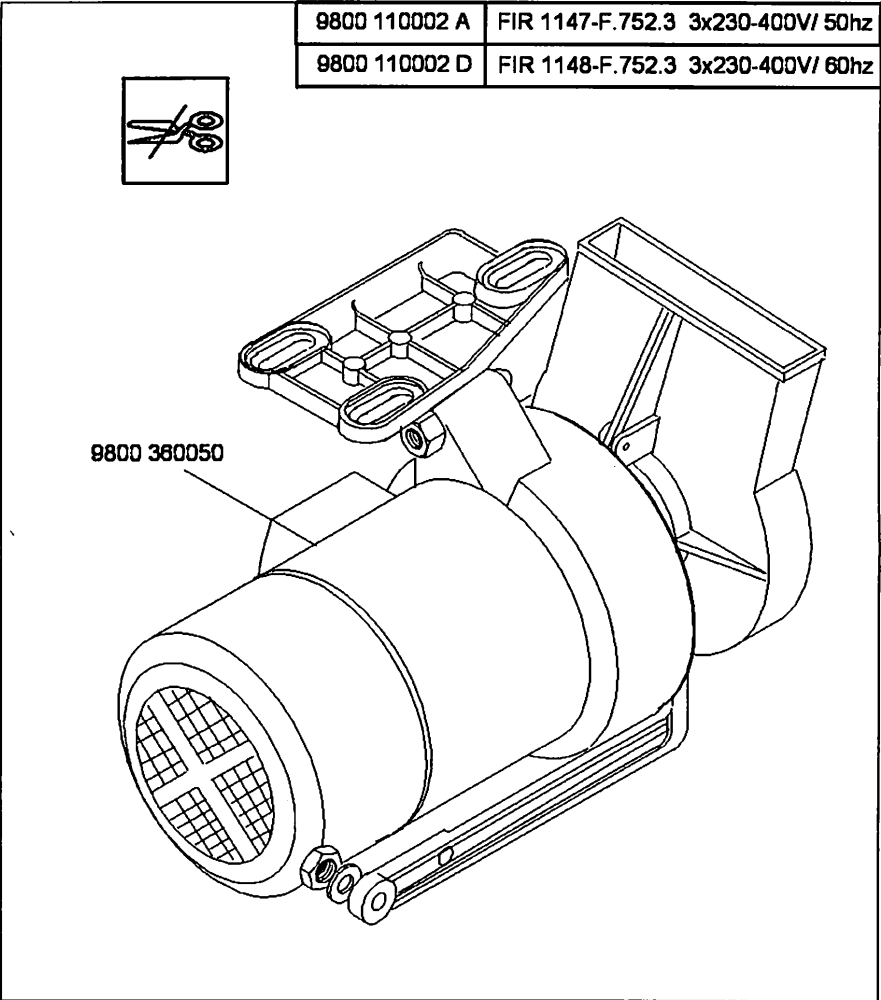

Cl. 868

Ausgabe/Edition 8.2008

Netz	n1/min	1	2
3x230V-400V/50 HZ	2500	9130 500080	9130 104400
3x230V-400V/60 HZ	2500	9130 500050	9130 104350
3x230V-400V/50 HZ	2000	9130 500050	9130 104350
3x230V-400V/60 HZ	2000	9130 500010	9130 104350

Part set for / Teilesatz für FIR 1147-F752.3 und FIR 1148-F752.3

37

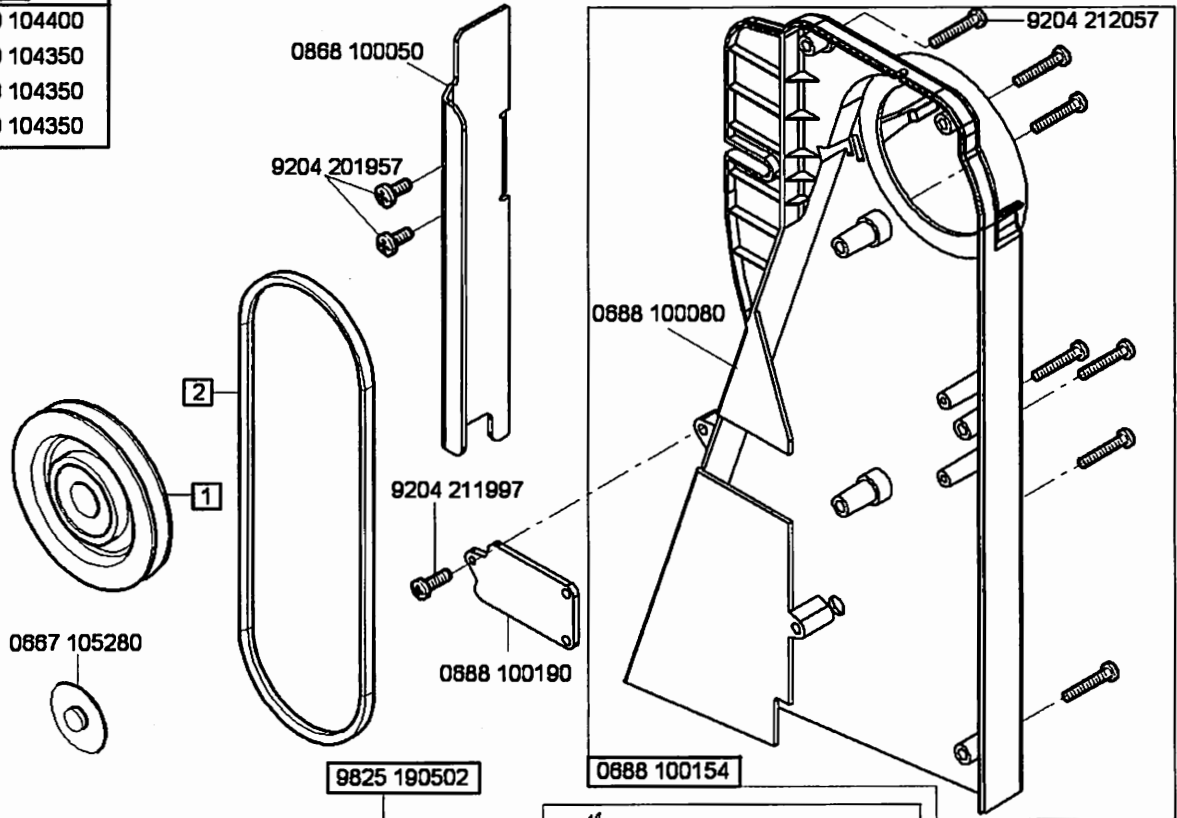
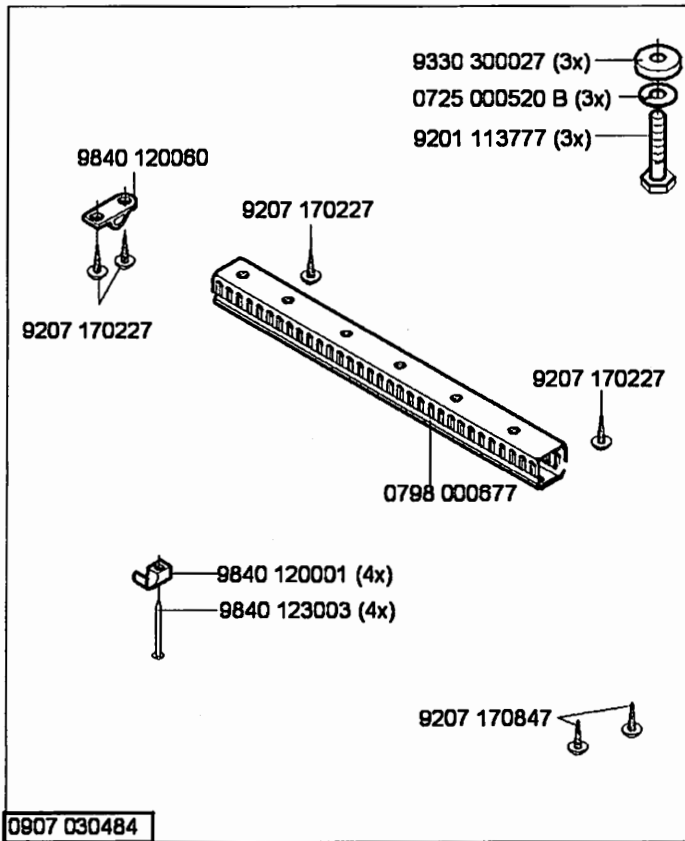

9870 001003 = +

3x400V 50Hz

9870 001004 = +

3x230V 60Hz  
3x230V 50Hz

9825 190400

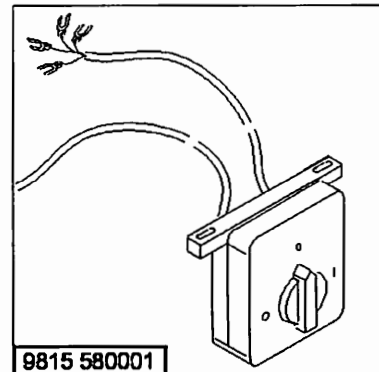

MG43 000410

Cl. 868

Ausgabe/Edition 8.2008

Part set for / Teilesatz für EFKA DC1550/DA321G

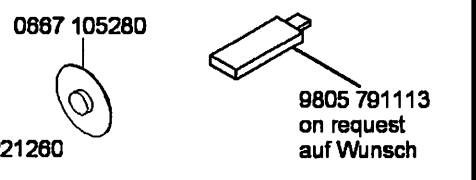
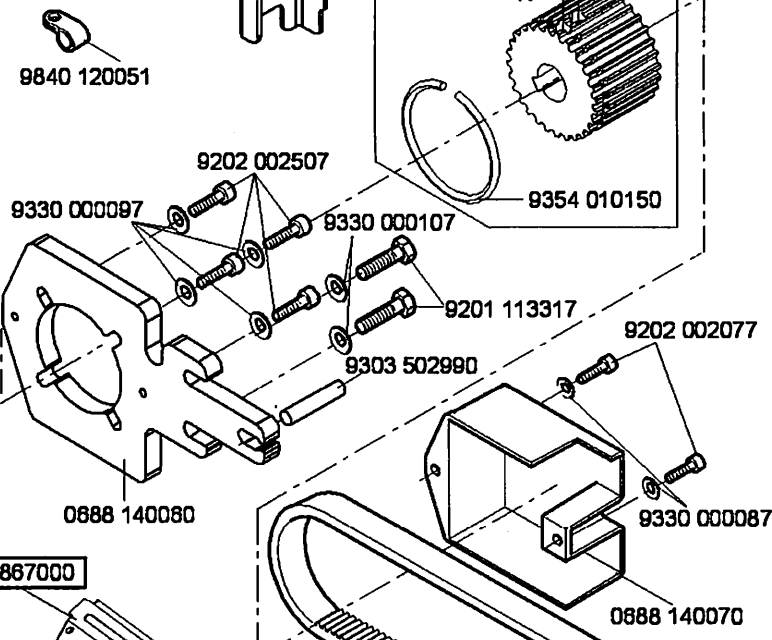
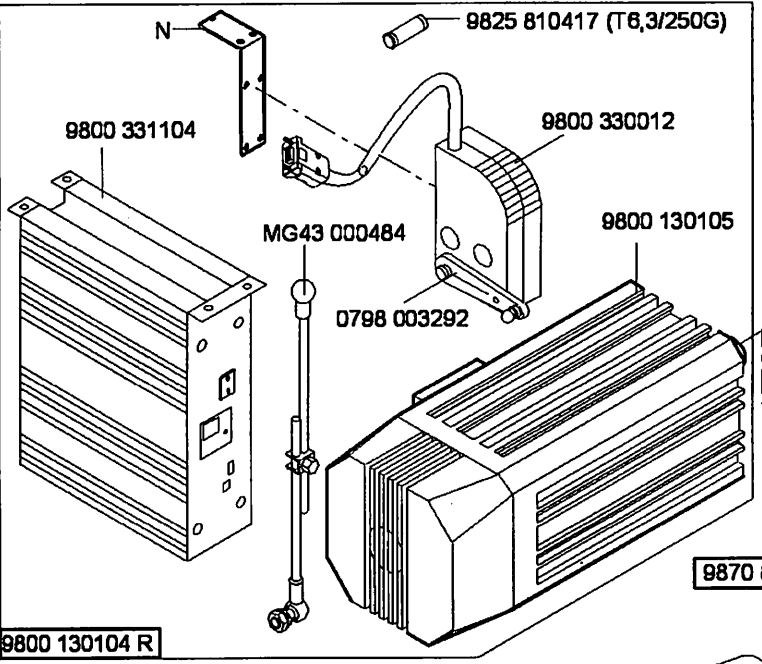
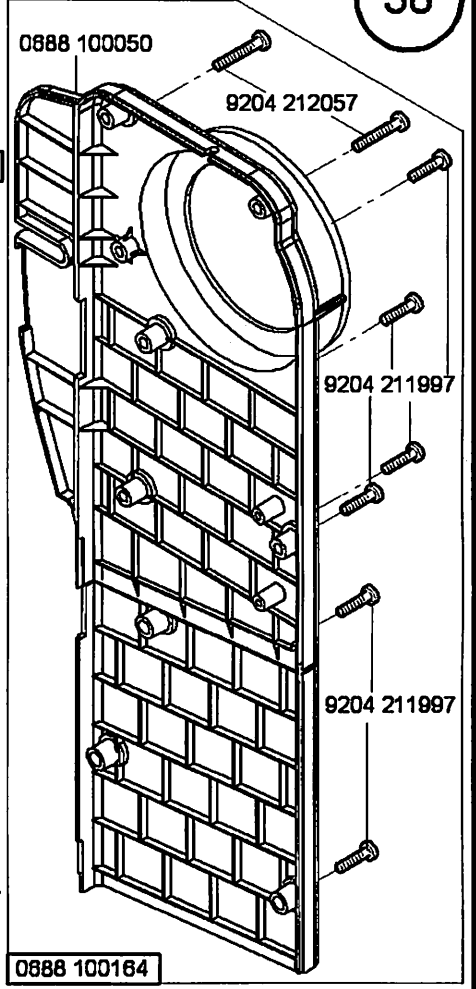
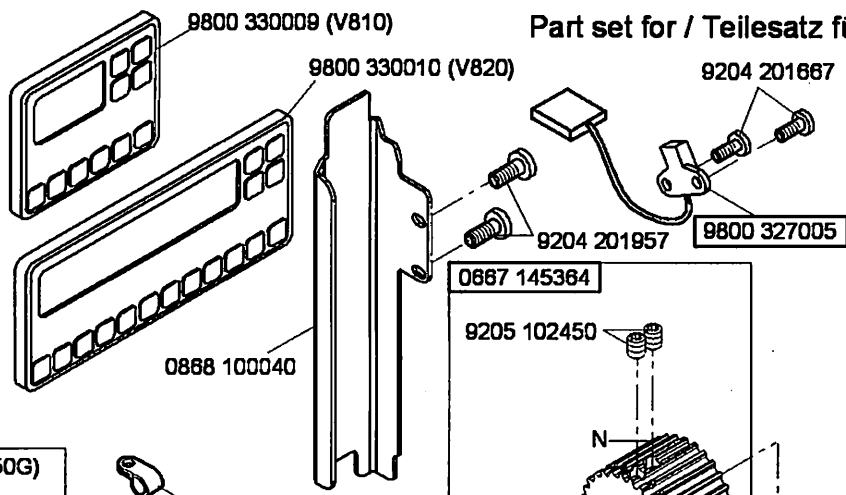
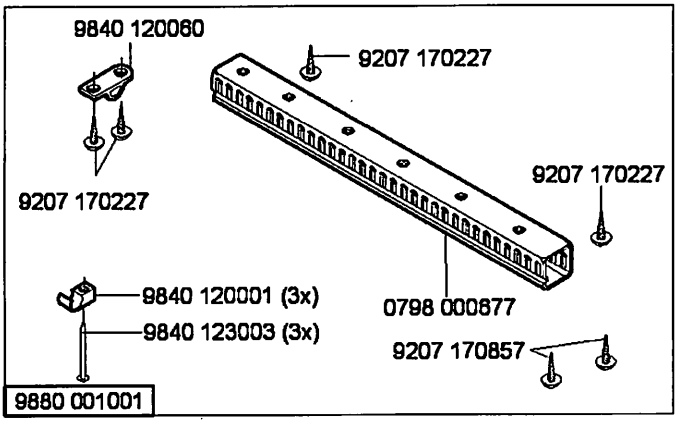

N - nicht als Einzelteil lieferbar  
not available as separate part

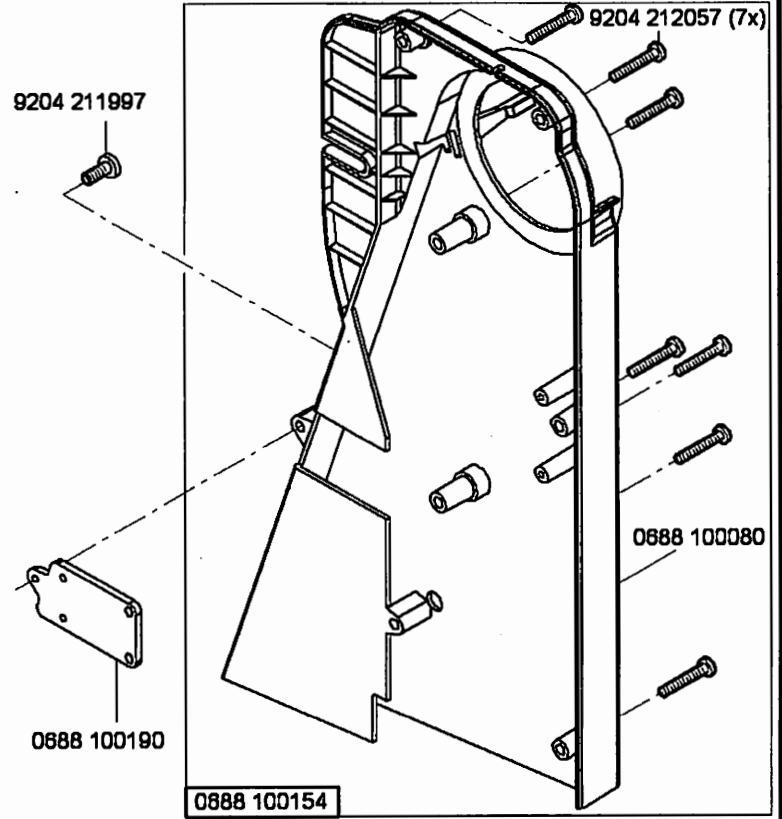
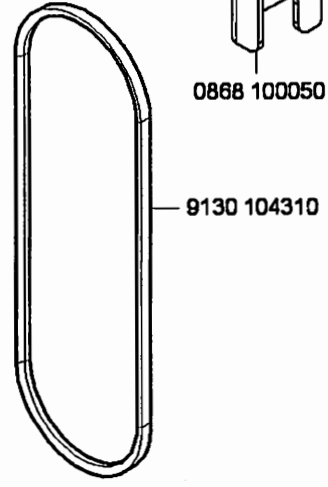
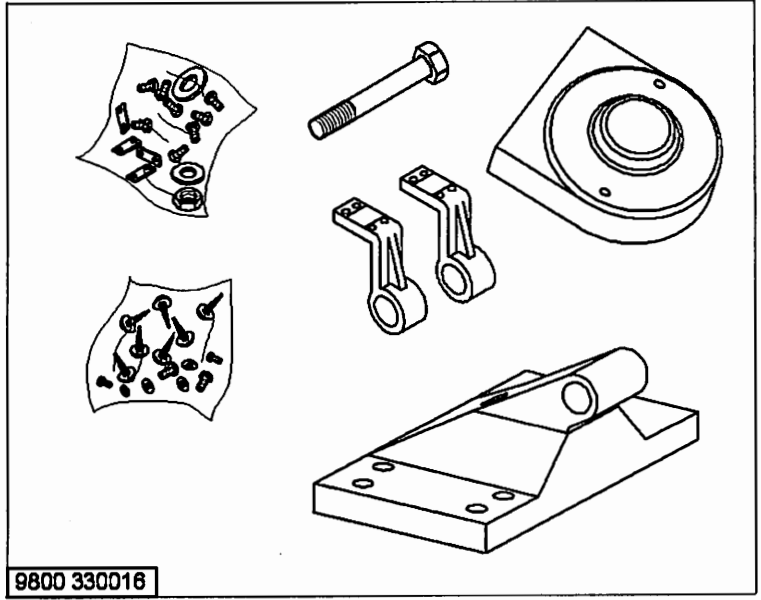
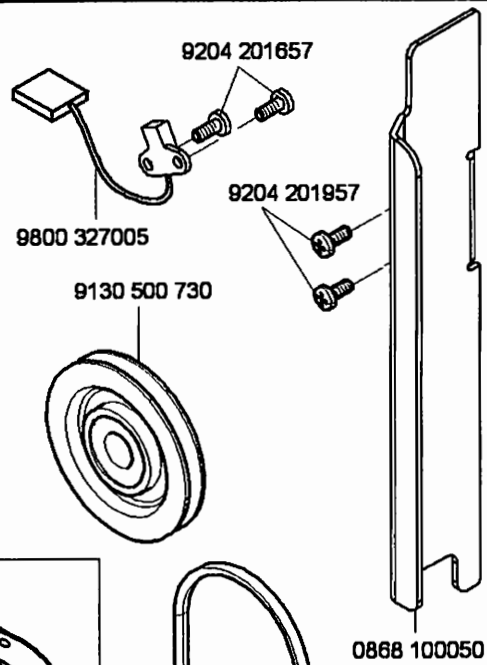
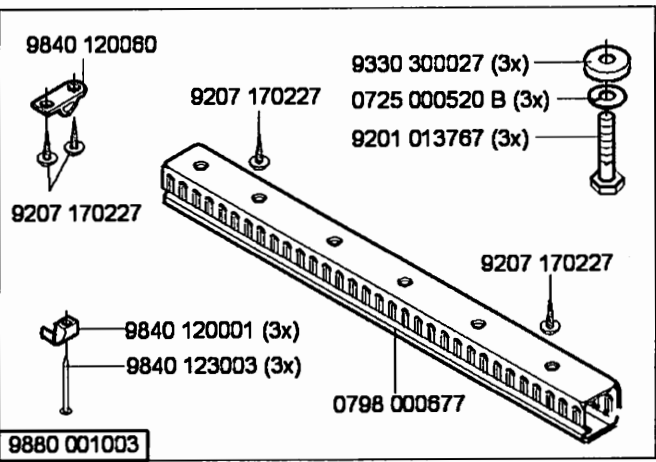

N - nicht als Einzelteil lieferbar  
not available as separate part

für EFKA DC1550DA321G

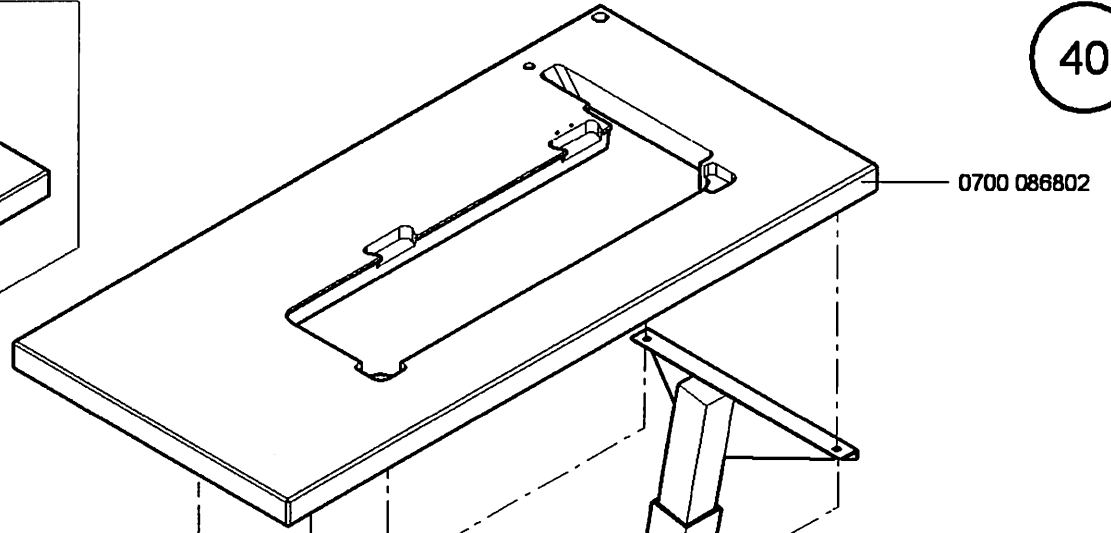
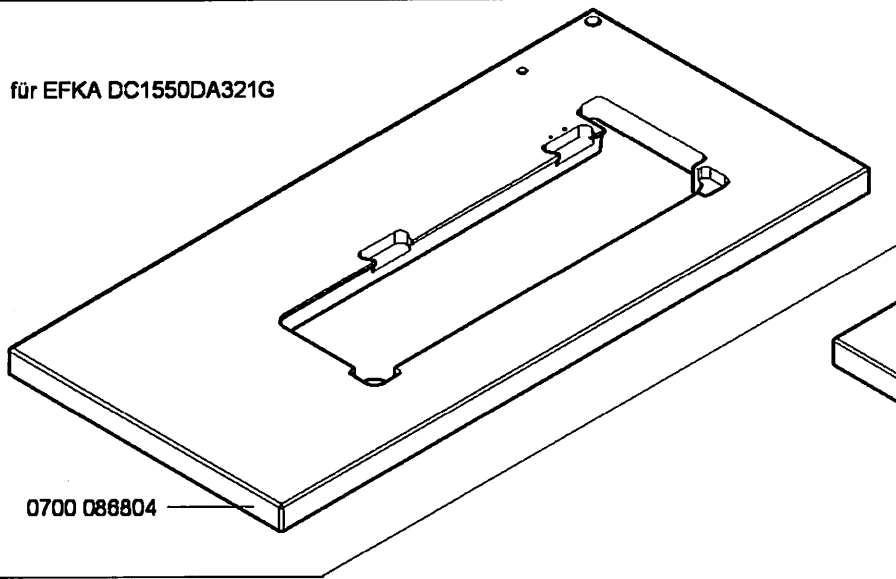

MG53 007511

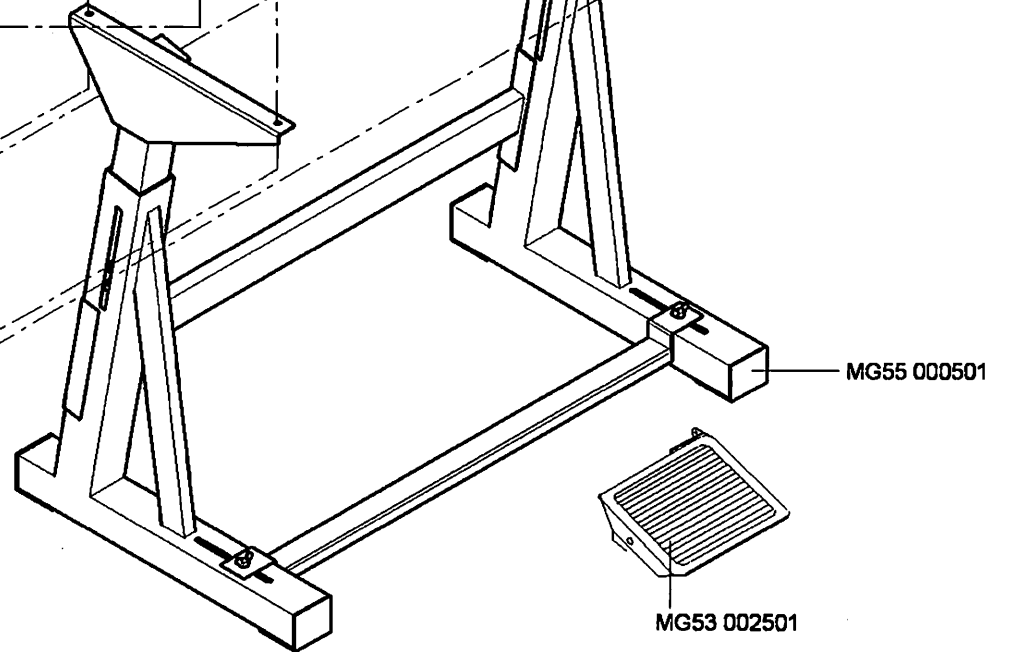
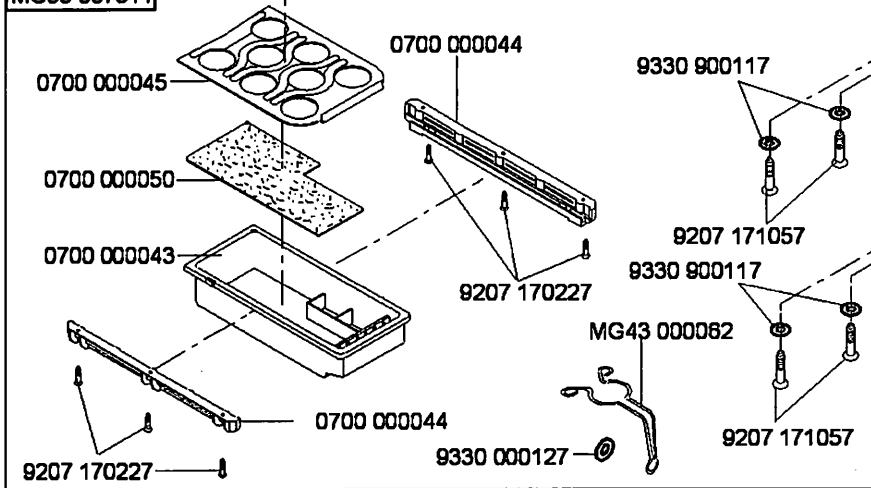

Cl. 868

Ausgabe/Edition 8.2008

auf Wunsch  
on request

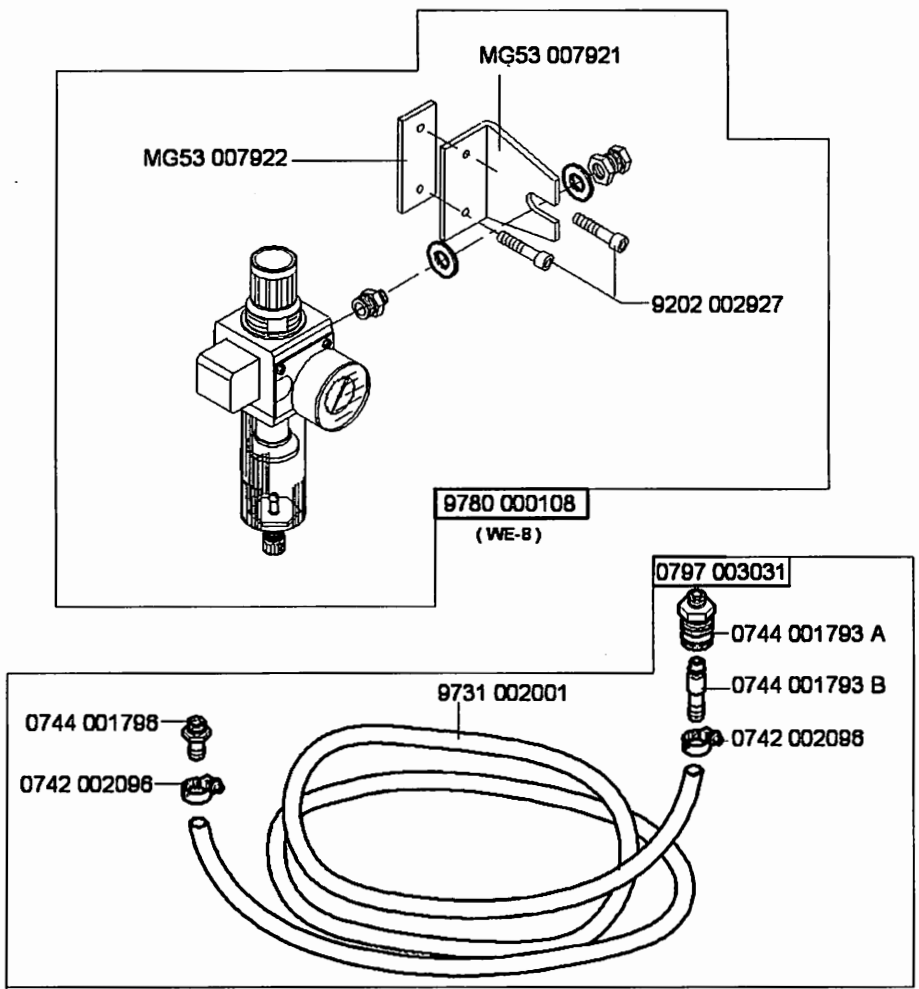

Cl. 868

Ausgabe/Edition 8.2008

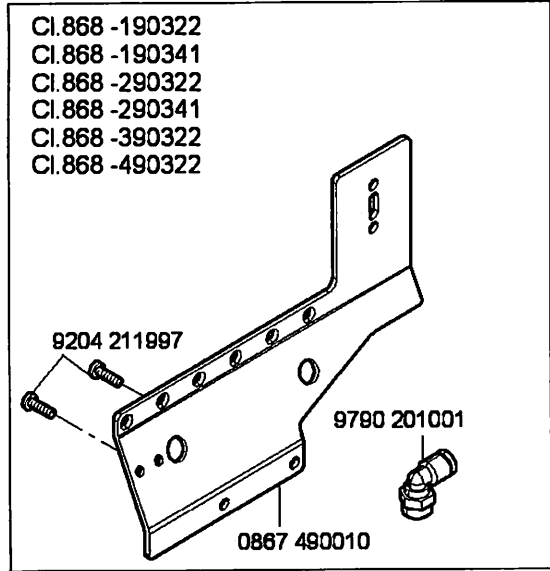
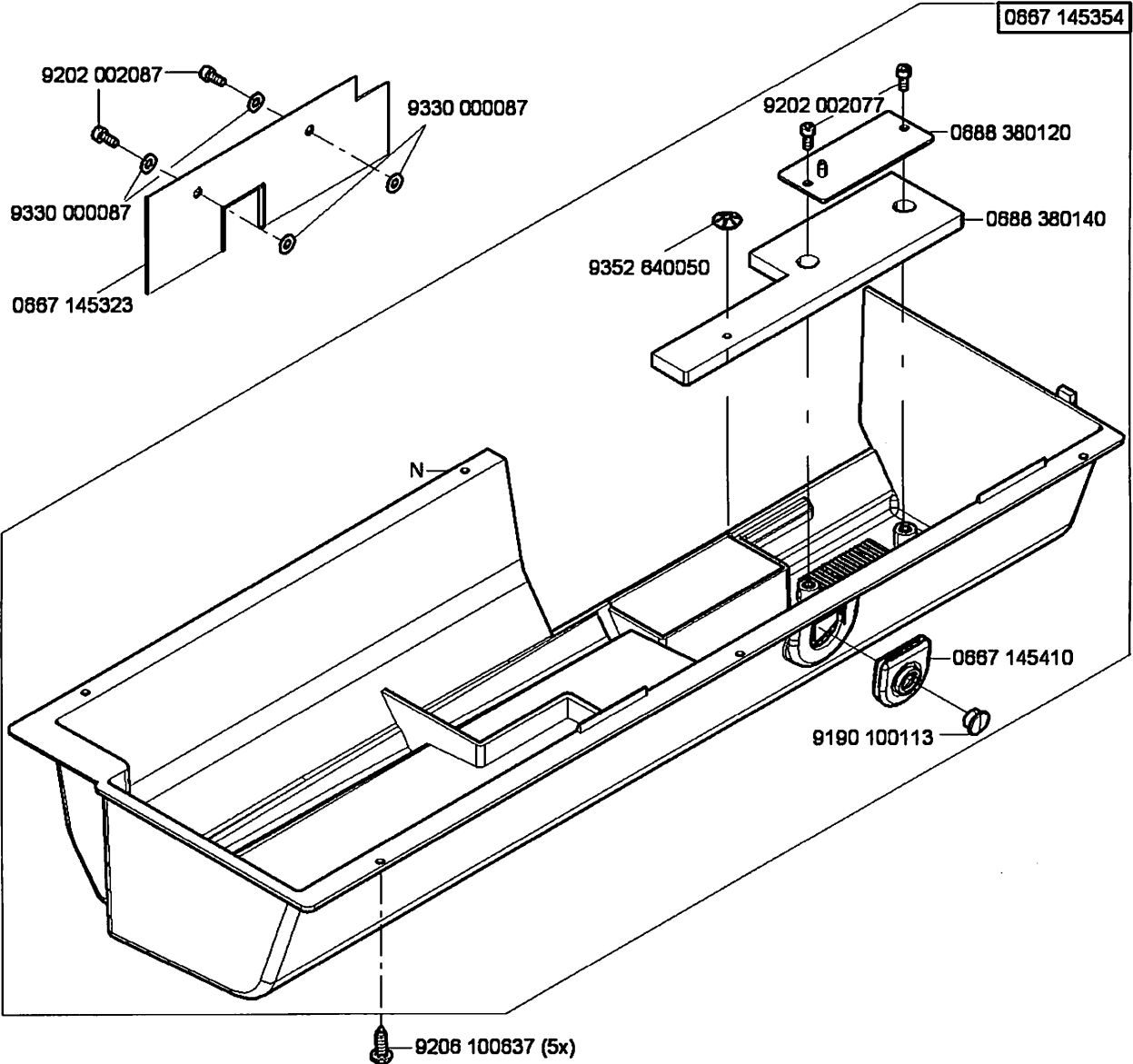
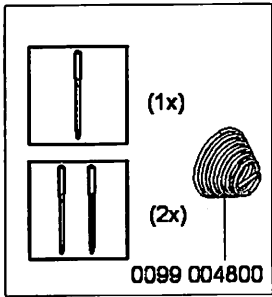

N - nicht als Einzelteil lieferbar  
not available as separate part

Cl. 868



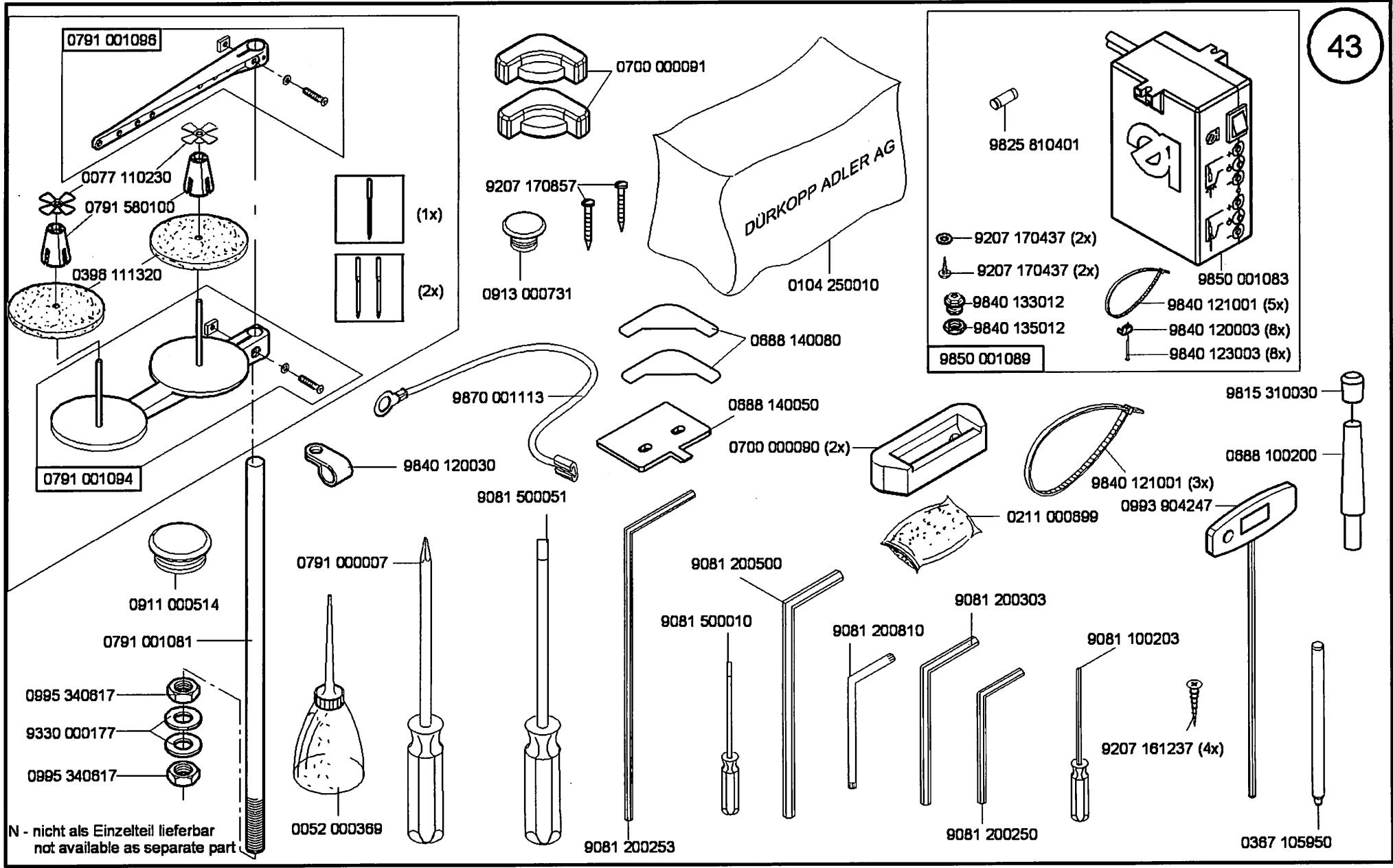

Cl. 868

Ausgabe/Edition 8.2008

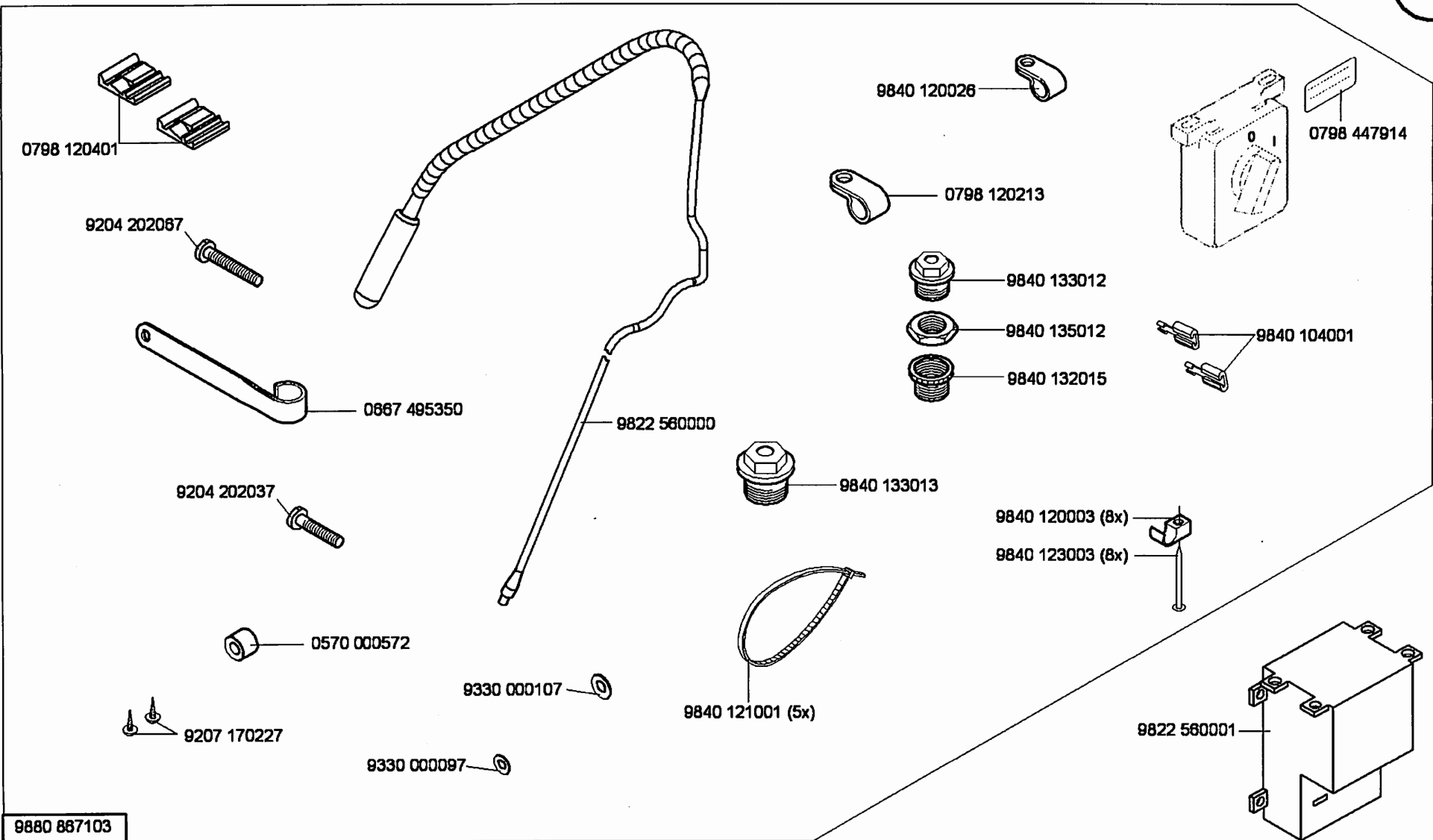

9880 887103

Cl. 868

Ausgabe/Edition 8.2008

N800 005655

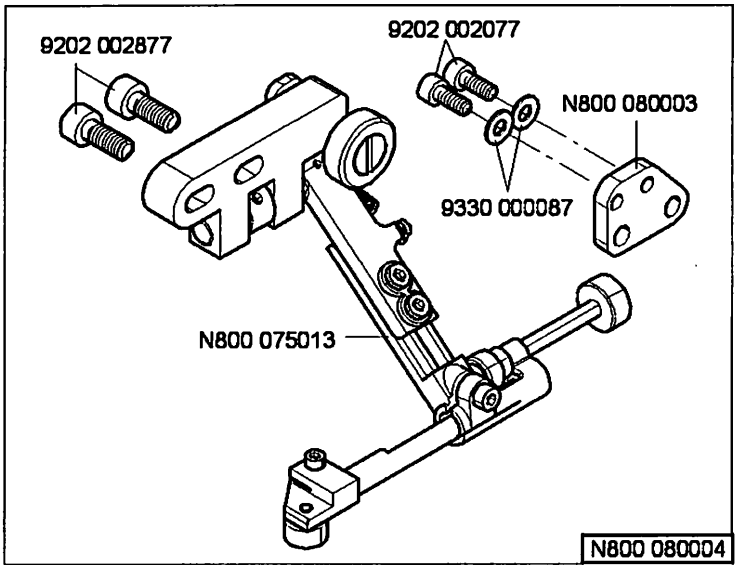
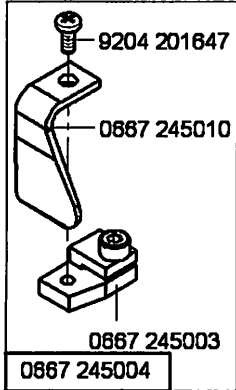

siehe Näherichtungen Blatt 1  
see sewing equipment page 1  
0867 590084

0867 105164

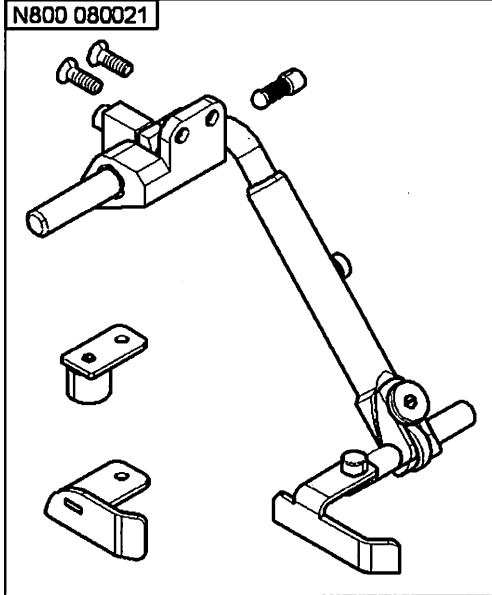
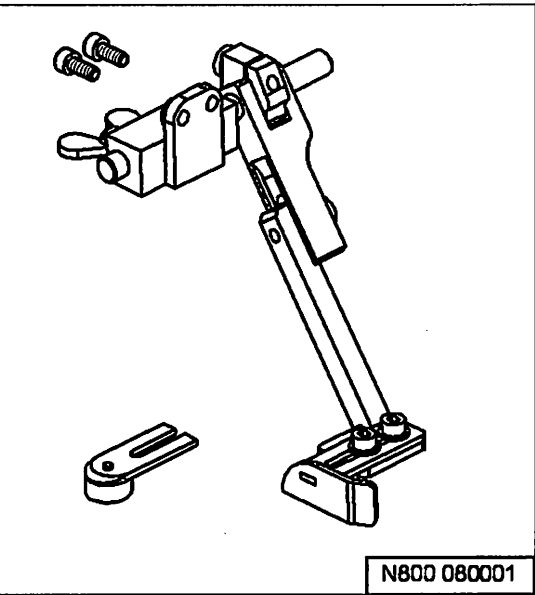
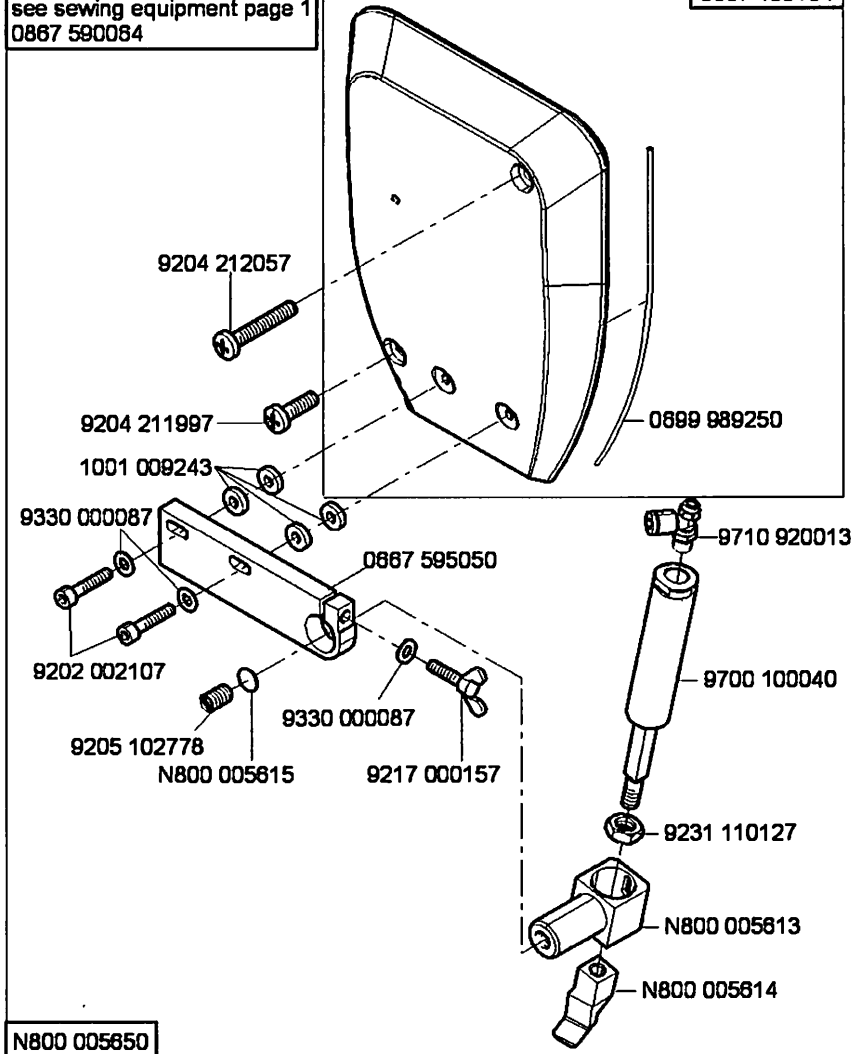

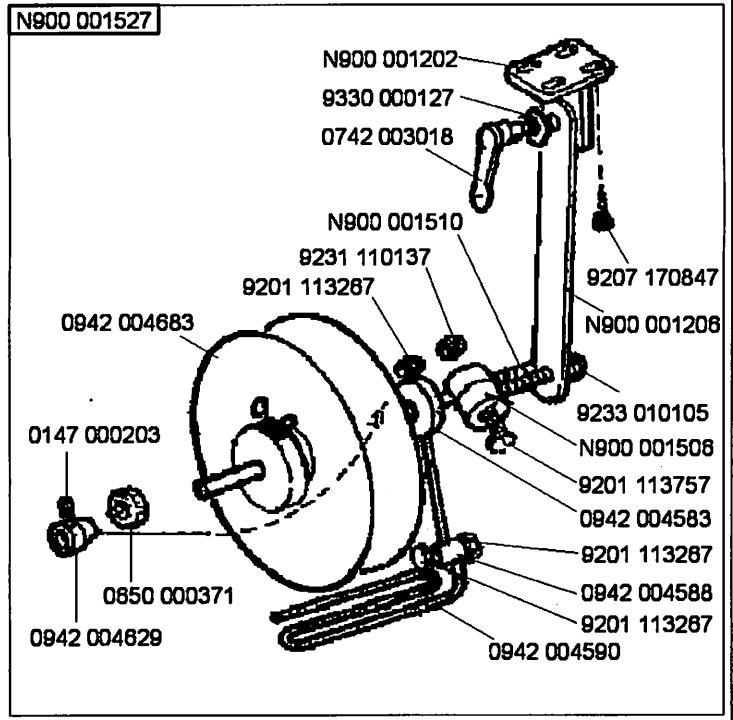
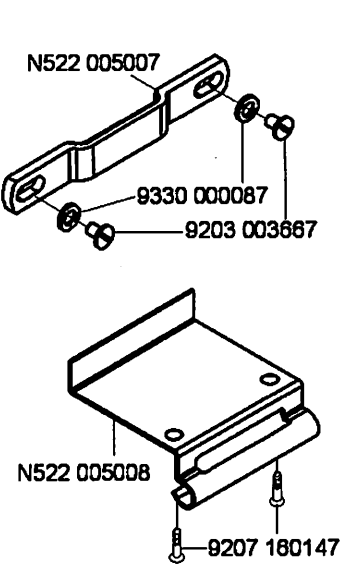
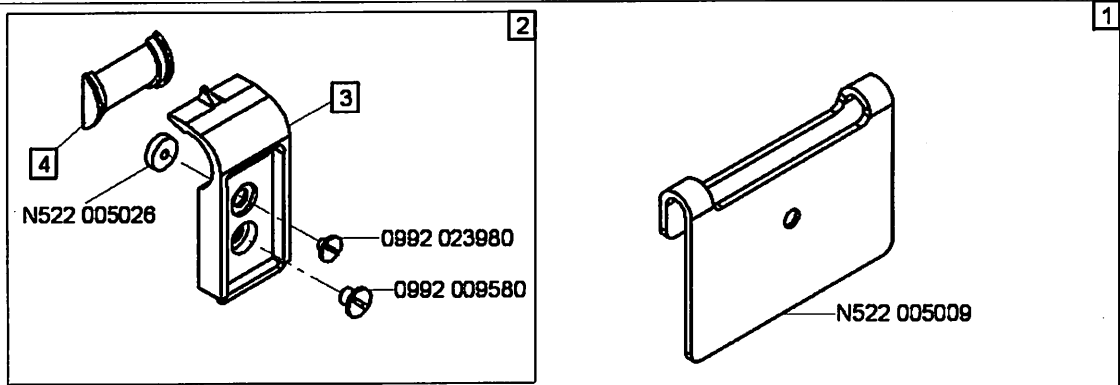

Pos.	Teile-Nr. / Part no.	NA / needle distance	Bandbreite / belt width
1	N522 025021	8	14
1	N522 025031	10	16
1	N522 025041	12	18
1	N522 025051	14	20
2	N522 005022	8	14
2	N522 005032	10	16
2	N522 005042	12	18
2	N522 005052	14	20
3	N522 005024	8	14
3	N522 005034	10	16
3	N522 005044	12	18
3	N522 005054	14	20
4	N522 005025	8	14
4	N522 005035	10	16
4	N522 005045	12	18
4	N522 005055	14	20

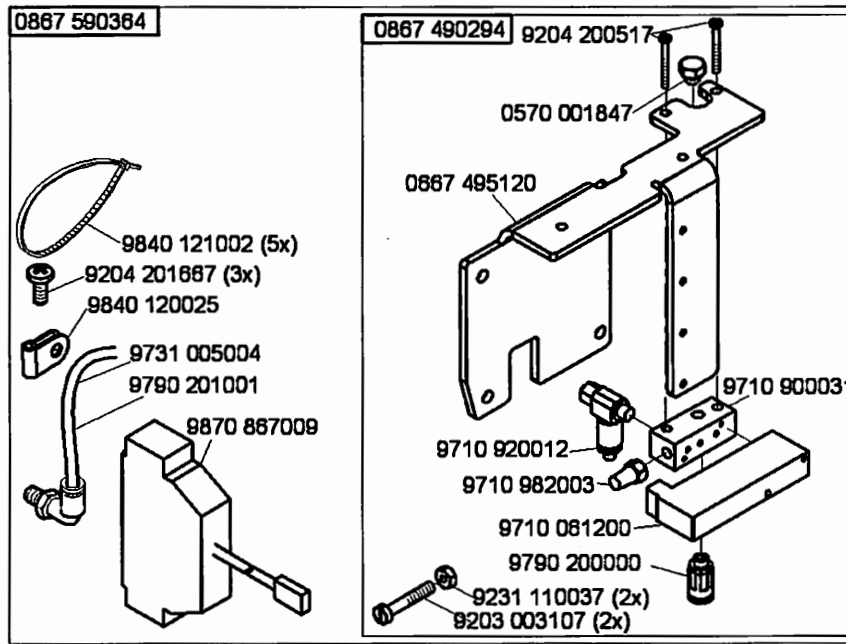
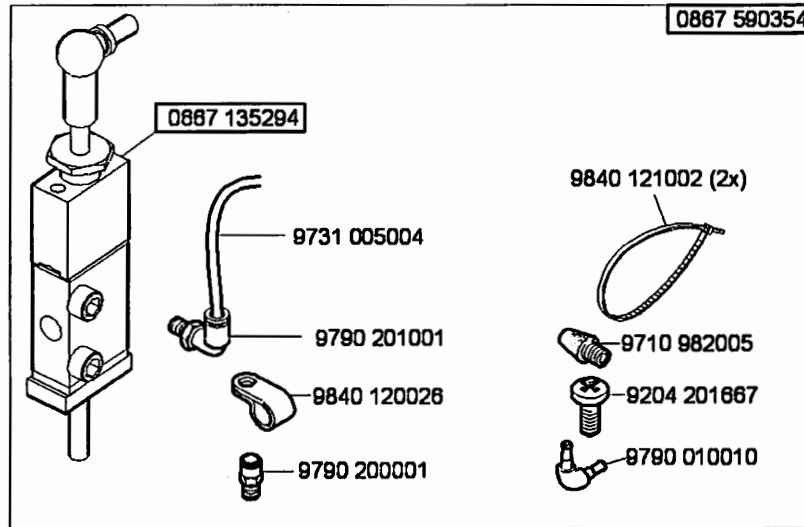
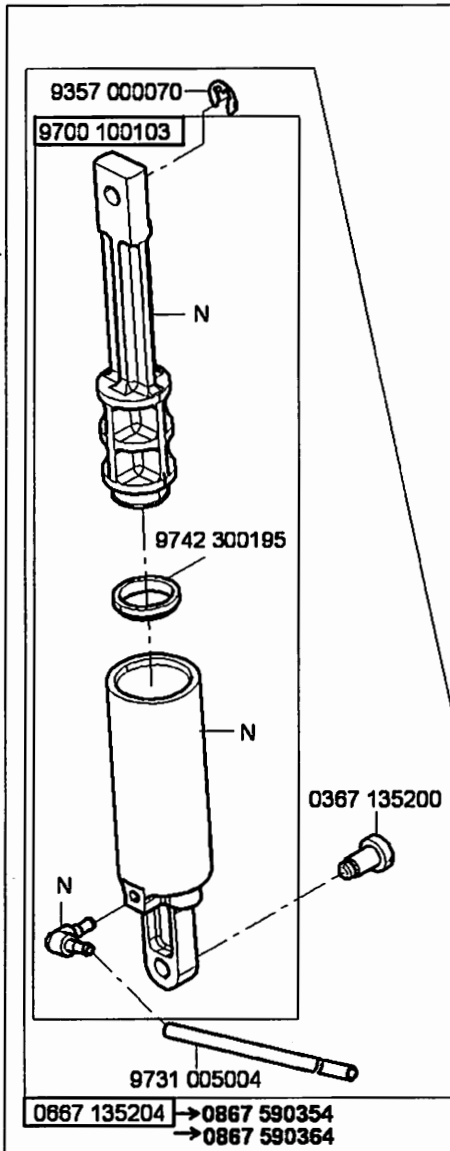

N - nicht als Einzelteil lieferbar  
not available as separate part

Teile-Nr./Part-No.	Tafel/Table	Teile-Nr./Part-No.	Tafel/Table	Teile-Nr./Part-No.	Tafel/Table	Teile-Nr./Part-No.	Tafel/Table	Teile-Nr./Part-No.	Tafel/Table
0002 007504 9500	35	0367 120100	3	0667 105060	30,31	0667 115430	21,23	0667 135190	6
0037 001280	21,22,23,24	0367 125020	6	0667 105080	2	0667 115440	22	0667 135204	12,47
0052 000369	43	0367 125194	3	0667 105120	30	0667 115444	22	0667 135294	47
0053 000350	21,23	0367 135200	12,47	0667 105144	30	0667 115490	21	0667 135300	6
0061 001050	21,22,23,24	0367 145110	9	0667 105164	45	0667 115514	21	0667 145044	2
0077 110230	43	0367 145180	6,7,8	0667 105190	32	0667 115520	21,22,23,24	0667 145074	2
0099 004910	21,22,23,24	0367 150860	29	0667 105254	32	0667 115530	21,22,23,24	0667 145264	2
0104 250010	43	0367 165080	7	0667 105280	37,38,39	0667 115580	23,24	0667 145303	2
0147 000203	46	0367 165120	6,7	0667 110340	30,31	0667 115590	21,22,23,24	0667 145323	42
0211 000007	16,17	0367 165140	7	0667 115070	21,23	0667 115600	21,22	0667 145354	42
0211 000699	43	0367 165970	13,26	0667 115080	21,23	0667 115610	21,22,23,24	0667 145364	38
0211 004516	3	0367 315014	6	0667 115090	21,23	0667 115620	21,22	0667 145410	42
0216 000603	20	0367 315024	6	0667 115094	23	0667 115630	21,22,23,24	0667 145464	2
0219 000321	30,31	0367 315130	6	0667 115110	23	0667 115640	21,22,23,24	0667 150830	15
0244 000403	20	0367 385133	3	0667 115120	21,23	0667 115760	30	0667 150850	15
0244 000700	16,17,20	0367 495010	30,31	0667 115130	21,23	0667 115864	24	0667 155424	16,17
0245 001660 A	14	0396 111320	43	0667 115134	21,23	0667 115874	24	0667 155440	16
0265 000911	21,23	0467 110220	21,22,23,24	0667 115140	21,23	0667 125033	3	0667 155450	17
0271 000275	20	0467 150120	15	0667 115150	21,23	0667 125060	5	0667 155720	17
0271 001639	25,26	0467 150130	14	0667 115160	21,23	0667 125100	3	0667 155840	31
0291 000159	3	0467 150440	14,15	0667 115170	21,22,23,24	0667 125143	3	0667 155930	31
0291 000334	25,26	0491 030652	7	0667 115180	21,22,23,24	0667 125150	3	0667 155940	2
0291 000347	30,31	0556 000821 A	25,26	0667 115203	21,22,23	0667 125160	3	0667 155950	16
0291 000537	29	0558 000599	19	0667 115210	21,22,23,24	0667 125243	3	0667 156180	15
0291 000538	29	0570 000572	44	0667 115220	24	0667 125254	3	0667 156190	14
0367 100190	17	0570 001847	28,31,47	0667 115250	21,22,23,24	0667 135013	9	0667 156320	14
0367 105083	6,7,8	0650 000371	46	0667 115280	30	0667 135033	9	0667 156330	15
0367 105180	6,7,8	0667 100050	3,4	0667 115290	21,22,23,24	0667 135073	11	0667 156440	15
0367 105910	35	0667 105023	32,33	0667 115320	3	0667 135094	9	0667 160170	25,26
0367 105950	43	0667 105024	33	0667 115354	22	0667 135103	9	0667 160350	25,26
0367 110340	21,22,23,24	0667 105040	1	0667 115360	21,23	0667 135124	9	0667 160374	26
0367 110360	21,22,23,24	0667 105053	1	0667 115420	21,23	0667 135150	11	0667 160480	6,7

Teile-Nr./Part-No.	Tafel/Table	Teile-Nr./Part-No.	Tafel/Table	Teile-Nr./Part-No.	Tafel/Table	Teile-Nr./Part-No.	Tafel/Table	Teile-Nr./Part-No.	Tafel/Table
0667 165063	7	0667 245003	45	0667 495120	47	0688 380163	4	0818 160024	10
0667 165130	6	0667 245004	45	0667 495290	28	0699 979104	11,16,17,29	0818 160040	10
0667 165190	27	0667 245010	45	0667 495304	30	0699 989250	30,31,32,33,45	0818 160210	7
0667 165210	27	0667 310563	6	0667 495350	44	0700 000043	40	0867 120024	4
0667 165220	27	0667 315053	6	0667 595050	45	0700 000044	40	0867 120043	4
0667 165243	25,26	0667 315113	6	0688 100050	38	0700 000045	40	0867 120070	4
0667 165250	25,26	0667 315150	6,7,8,9	0688 100080	37,39	0700 000050	40	0867 120080	4
0667 165284	25,26	0667 315164	6	0688 100154	37,39	0700 000090	43	0867 120090	4
0667 165290	25,26	0667 315174	13	0688 100164	38	0700 000091	43	0867 120100	4
0667 165304	25,26	0667 315243	5	0688 100173	1	0700 086802	40	0867 120110	4
0667 165354	26	0667 315253	5	0688 100190	39	0700 086804	40	0867 120120	4
0667 165390	8	0667 315280	6	0688 100200	43	0725 000520 B	37,39	0867 120130	4
0667 165403	8	0667 315290	6	0688 130260	11	0742 002096	41	0867 120140	4
0667 165423	8	0667 315300	32,33	0688 130280	9	0742 003018	46	0867 120150	4
0667 165464	27	0667 315314	6	0688 130290	9	0744 001155	22,24	0867 120160	4
0667 165500	8	0667 315320	6	0688 140020	34	0744 001793 A	41	0867 120170	4
0667 165550	7	0667 315330	6	0688 140050	43	0744 001793 B	41	0867 120220	31
0667 165570	27	0667 315354	33	0688 140060	38	0744 001796	41	0867 120233	31
0667 165580	7	0667 315364	32,33	0688 140070	38	0767 150590	14,15	0867 120250	31
0667 170070	20	0667 315423	8	0688 140080	43	0791 000007	43	0867 120270	31
0667 170120	20	0667 355150	19	0688 150024	2	0791 001081	43	0867 120280	4
0667 175010	20	0667 355173	19	0688 150290	16,17	0791 001094	43	0867 120294	31
0667 175020	20	0667 355174	19	0688 160463	25,26	0791 001096	43	0867 120300	4
0667 175030	20	0667 355240	29	0688 350020	19	0791 580100	43	0867 120320	31
0667 175034	20	0667 385013	6,7	0688 350120	19	0797 003031	41	0867 120340	4
0667 175040	20	0667 385033	29	0688 350200	19	0798 000677	37,38,39	0867 120350	4
0667 175053	20	0667 385070	17	0688 350254	19	0798 003292	38	0867 120360	4
0667 175060	20	0667 385143	29	0688 350264	19	0798 120213	44	0867 120370	4
0667 175083	20	0667 385180	30	0688 380040	29	0798 120401	44	0867 120380	4
0667 175104	20	0667 385220	29	0688 380120	42	0798 447914	35,44	0867 120390	31
0667 175114	20	0667 495104	26	0688 380130	29	0798 500088	35	0867 120400	4
0667 235010	3	0667 495110	26	0688 380140	42	0818 160010	10	0867 120410	4



Teile-Nr./Part-No.	Tafel/Table	Teile-Nr./Part-No.	Tafel/Table	Teile-Nr./Part-No.	Tafel/Table	Teile-Nr./Part-No.	Tafel/Table	Teile-Nr./Part-No.	Tafel/Table
0867 120420	4	0868 150170	16,17	0868 310013	5	0942 004583	46	9122 200161	1
0867 120423	4	0868 150190	19	0868 310023	5	0942 004588	46	9122 322200	5
0867 120440	4	0868 150220	16,17	0868 310033	5	0942 004590	46	9126 102520	6,7,25,26
0867 120520	31	0868 150230	18	0868 310043	5	0942 004629	46	9126 102540	6,7,25,26
0867 120533	4	0868 150240	16,17	0868 310053	5	0942 004683	46	9126 300089	16,17
0867 120564	31	0868 150250	16,17	0868 310080	6	0992 001020	29	9126 300201	5
0867 120574	31	0868 150260	16,17	0868 310084	6	0992 009580	46	9129 024235	3,4
0867 140030	34	0868 150283	16	0868 310090	6	0992 016580	14,15	9130 104310	39
0867 160620	6	0868 150293	17	0868 320030	10	0992 023560	14,15	9130 104350	37
0867 160630	6	0868 150310	16,17	0868 320040	10	0992 023577	14,15	9130 104400	37
0867 160640	6	0868 150320	16,17	0868 320050	10	0992 023980	46	9130 221180	2
0867 310430	6	0868 150330	16,17	0868 350043	19	0993 904247	43	9130 221260	38
0867 310440	6	0868 150340	16,17	0868 350060	19	0995 340617	43	9130 500010	37
0867 490010	42	0868 150400	14	0868 350093	19	0998 881610	6,27	9130 500050	37
0867 490084	31	0868 150414	14	0868 350140	19	0998 912080	3	9130 500080	37
0867 490294	47	0868 150434	14	0868 350150	19	0999 201114	34	9190 100113	42
0867 590354	47	0868 150450	15	0868 350160	19	0999 220752	29	9190 100155	32,33
0867 590364	47	0868 150464	15	0868 350170	19	0999 220851	31	9190 100226	16,17
0867 590640	31	0868 150484	15	0868 350180	19	1001 001162	30,31,34	9190 400120	25
0868 100040	38	0868 150510	14	0868 350190	19	1001 009243	7,45	9199 000004	28
0868 100050	37,39	0868 150520	15	0868 350194	19	9041 100015	6,7,16,17	9201 013767	39
0868 130020	11	0868 160014	7	0868 380024	29	9041 100025	3	9201 113267	46
0868 140040	10	0868 160023	7	0868 380030	29	9041 100030	16,17	9201 113317	38
0868 140100	18	0868 160034	7	0887 380010	29	9041 100035	29	9201 113757	46
0868 140170	16,17	0868 160054	7	0888 150163	16,17	9041 100203	29,43	9201 113777	37
0868 140200	18	0868 160064	25,26	0891 003342	28,31	9081 200250	43	9202 001657	16,17
0868 150010	16,17	0868 160070	10	0902 004102	4	9081 200253	43	9202 001658	4
0868 150083	16,17	0868 160080	7	0907 030484	37	9081 200303	43	9202 001667	31
0868 150100	18	0868 160120	25,26	0911 000290	30	9081 200500	43	9202 001678	3,2
0868 150110	16,17	0868 160144	8	0911 000514	43	9081 200810	43	9202 002057	6,7,29,31
0868 150120	16,17	0868 160223	10	0913 000731	43	9081 500010	43	9202 002063	29
0868 150160	16,17	0868 160240	7	0933 001544	29	9081 500051	43		

Teile-Nr./Part-No.	Tafel/Table	Teile-Nr./Part-No.	Tafel/Table	Teile-Nr./Part-No.	Tafel/Table	Teile-Nr./Part-No.	Tafel/Table	Teile-Nr./Part-No.	Tafel/Table
9202 002077	7,10,16,17,19,25, 26,30,31,35,38, 42,45	9204 002363	34	9205 102778	45	9330 000027	4,26	9354 010210	2
9202 002078	3	9204 101657	6	9205 121558	16,17	9330 000047	16	9354 400800	4,29
9202 002087	19,27,29,42	9204 200517	28,31,47	9205 121868	19	9330 000067	16,17,21,22,23,24	9357 000050	19
9202 002088	26	9204 201067	20,26,28	9205 122488	16,17	9330 000087	3,5,16,17,21,22, 23,24,25,26,31, 38,42,45,46	9357 000070	6,7,11,12,13,20, 25,26,31,47
9202 002097	25,26,35	9204 201647	21,22,23,24,26, 30,31,34,45	9205 162597	11,29,42	9330 000097	2,38,44	9357 000080	8,21,23
9202 002098	5,7,9,19,25,26	9204 201657	3,39	9207 161237	43	9330 000107	38,44	9357 000090	5,6
9202 002107	19,45	9204 201667	3,4,20,28,29,31, 38,47	9207 170227	31,37,38,39,40,44	9330 000127	11,46	9357 000100	25,26
9202 002497	10	9204 201677	31	9207 170437	30,31,35,43	9330 000177	43	9357 000129	5,6,7,25,26,27
9202 002507	38	9204 201698	42	9207 170847	37,46	9330 000117	16,17	9400 000088	16,17
9202 002877	45	9204 201957	37,38,39	9207 170857	38,43	9330 300027	37,39	9400 000227	10
9202 002888	26	9204 202037	30,31,44	9217 000157	45	9330 700107	32,33	9700 100040	45
9202 002908	16,17	9204 202067	44	9217 300507	4,21,23	9330 900117	40	9700 100094	13
9202 002918	6	9204 211997	2,6,7,25,26,30,31, 32,33,37,38,39, 42,45	9225 201750	3	9330 110037	20	9700 100100	26,27
9202 002927	9,41	9204 212057	37,38,39,45	9225 201770	21,22,23,24,30,35	9331 110037	21,23	9700 100103	12,47
9202 003738	30,31	9204 301467	28,31	9230 000067	2	9332 500137	34	9710 061200	28,31,47
9202 022467	29	9204 301487	20	9231 000387	9	9333 000090	19	9710 900031	47
9202 042067	16,17	9204 302217	13,26,27	9231 110037	47	9334 000050	16,17	9710 900032	31
9202 042077	16,17	9204 431657	10,16,17,22,24	9231 110127	45	9334 000051	3,6,7,11,20,25,26	9710 900037	28
9202 100537	2,17	9205 101528	16,17	9231 110137	46	9334 001630	4,5,8	9710 920012	28,31,47
9203 001807	4	9205 101827	3	9233 010105	46	9334 001640	5	9710 920013	45
9203 001827	4	9205 101868	30	9234 000067	25,26	9334 002190	29	9710 982003	28,31,47
9203 001868	26	9205 102188	4	9301 100991	4	9350 000087	16,17	9710 982005	47
9203 003107	47	9205 102303	6	9301 101001	4	9350 400800	19	9731 001035	16,17,29
9203 003137	31	9205 102450	10,16,17,19,38	9301 101551	16,17	9352 000050	16,17	9731 002001	41
9203 003167	31	9205 102467	1,2,5,6,7,8,9,11,1 3,16,17,19,25,26	9301 102203	6	9352 000080	42	9731 005004	12,13,22,24,26, 27,28,31,47
9203 003667	46	9205 102468	6	9301 102821	10	9352 640050	2	9731 007035	3
9203 100002	21,22,23,24,28,31	9205 102477	2,3,4,6,8,10,14, 15,21,23,25,26	9301 200660	16,17	9353 000350	2	9740 000607	32,33
9203 211830	14,15			9302 000100	29	9353 000420	2	9742 300190	13
9203 312412	3			9303 502990	38	9353 000470	1,2	9742 300195	12,47
9204 002077	29			9305 100350	21,22	9353 200173	19	9780 000108	41
				9305 100370	23,24	9354 010150	38		

Teile-Nr./Part-No.	Tafel/Table	Teile-Nr./Part-No.	Tafel/Table	Teile-Nr./Part-No.	Tafel/Table	Teile-Nr./Part-No.	Tafel/Table	Teile-Nr./Part-No.	Tafel/Table
9790 000490	29	9840 120001	37,38,39	9870 867002	26	N522 005044	46		
9790 010010	24,47	9840 120003	13,30,31,35,43,44	9870 867007	19	N522 005045	46		
9790 200000	28,47	9840 120025	13,16,17,47	9870 867009	47	N522 005052	46		
9790 200001	47	9840 120026	26,29,30,31,35, 44,47	9870 867010	31	N522 005054	46		
9790 201000	28,31			9880 001001	38	N522 005055	46		
9790 201001	42,47	9840 120028	29	9880 001003	39	N522 025021	46		
9790 202000	31	9840 120029	16,17,29	9880 867100	35	N522 025031	46		
9800 110002 A	36	9840 120030	43	9880 867101	28	N522 025041	46		
9800 110002 D	36	9840 120051	38	9880 867102	30	N522 025051	46		
9800 130104 R	38	9840 120060	37,38,39	9880 867103	44	N800 005613	45		
9800 130105	38	9840 120104	29,34	9880 867105	13	N800 005614	45		
9800 327005	38,39	9840 120105	27,29	9880 867113	31	N800 005615	45		
9800 330009	38	9840 121001	13,29,30,31,35, 43,44	9880 867114	31	N800 005650	45		
9800 330010	38	9840 121002	47	MG43 000062	40	N800 075013	45		
9800 330012	38	9840 123003	13,30,31,35,37, 38,39,43,44	MG43 000410	37	N800 080001	45		
9800 330016	39			MG43 000484	38	N800 080003	45		
9800 331104	38	9840 130007	29	MG53 002501	40	N800 080004	45		
9815 580001	37	9840 130008	29	MG53 007511	40	N800 080021	45		
9822 510003	35	9840 132015	30,31,35,44	MG53 007921	41	N900 001202	46		
9822 510013	35	9840 133012	30,31,35,43,44	MG53 007922	41	N900 001206	46		
9822 560001	44	9840 133013	30,31,35,44	MG55 000501	40	N900 001506	46		
9822 610000	35	9840 135012	30,31,35,43,44	N522 005007	46	N900 001510	46		
9822 642027	35	9850 001083	43	N522 005008	46	N900 001527	46		
9825 190400	37	9850 001089	43	N522 005009	46				
9825 190502	37	9850 867000	28	N522 005022	46				
9825 550001	28	9850 867001	29	N522 005024	46				
9825 810302	35	9850 867006	31	N522 005025	46				
9825 810401	43	9870 001003	37	N522 005026	46				
9825 810417	38	9870 001004	37	N522 005032	46				
9830 501010	28,31	9870 001112	13	N522 005034	46				
9830 502014	29	9870 001113	43	N522 005035	46				
9840 104001	30,31,35,44	9870 867000	38	N522 005042	46				

**Befestigungsteile für Nähmaschinen  
Fastening parts for Sewing equipment**

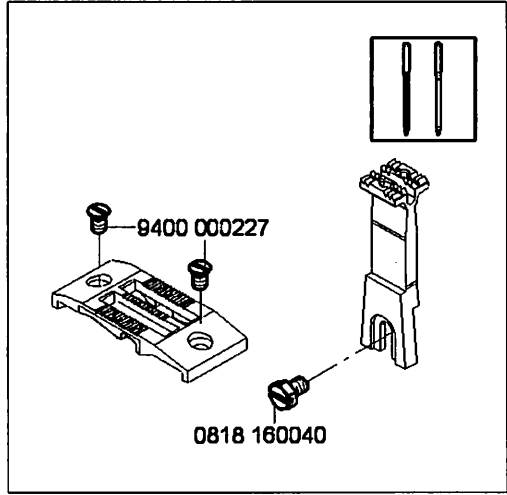
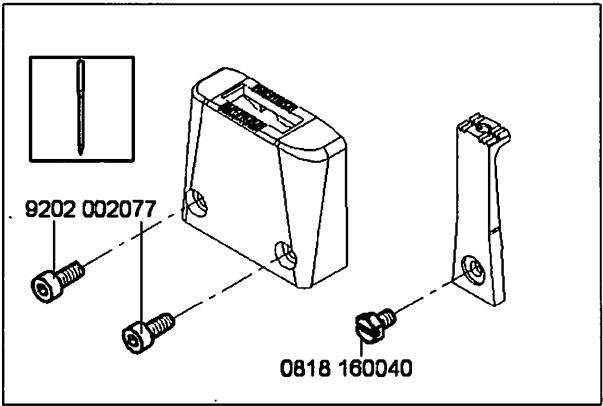
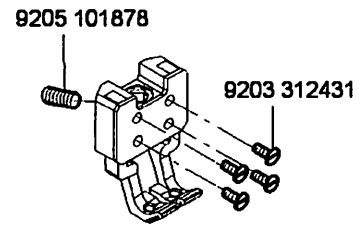
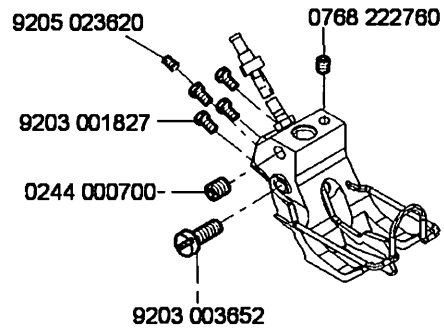
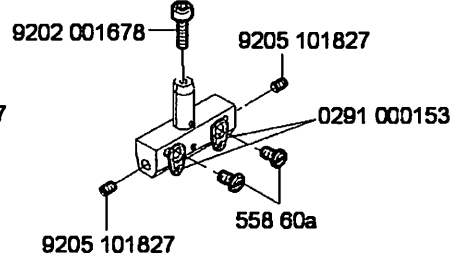
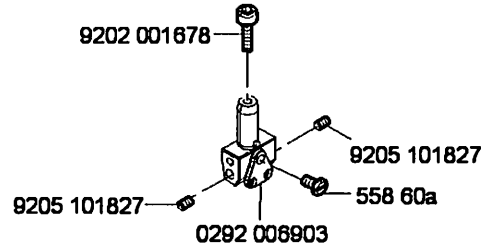
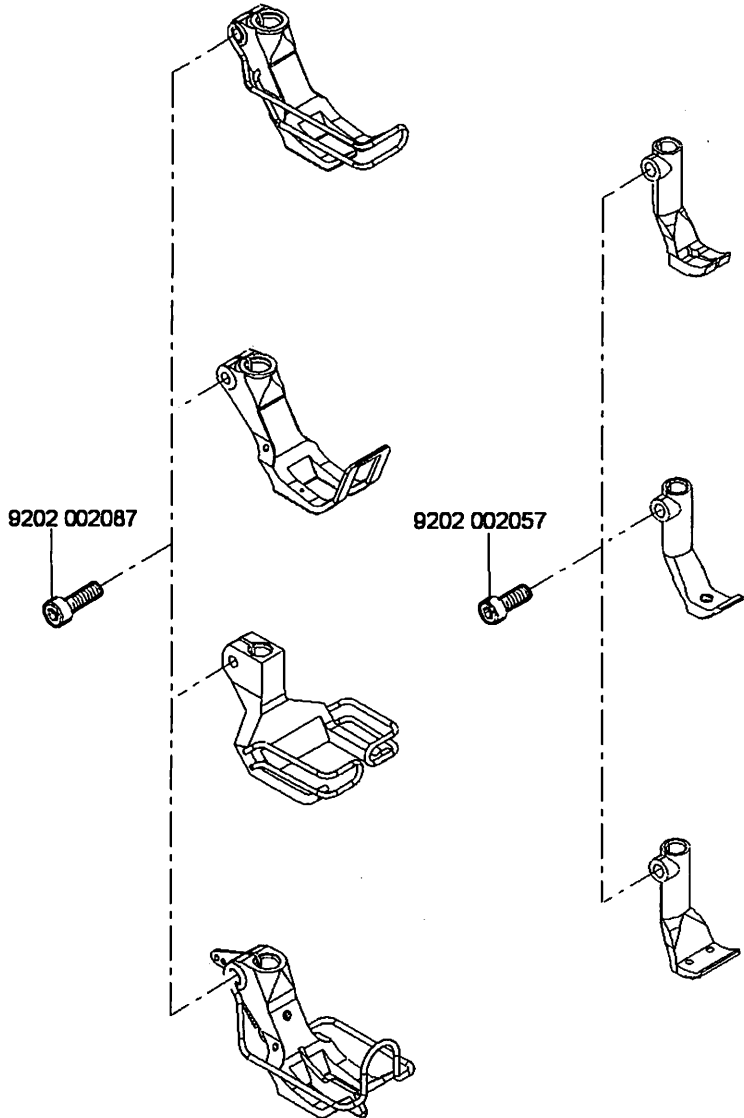

Cl. 868

Ausgabe/Edition 11.2008

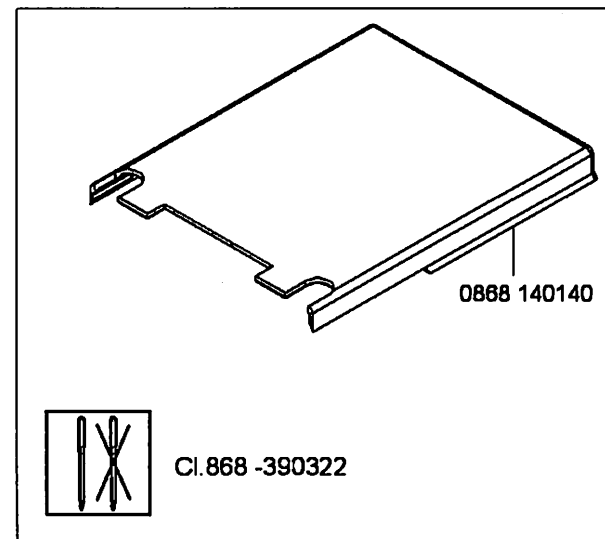
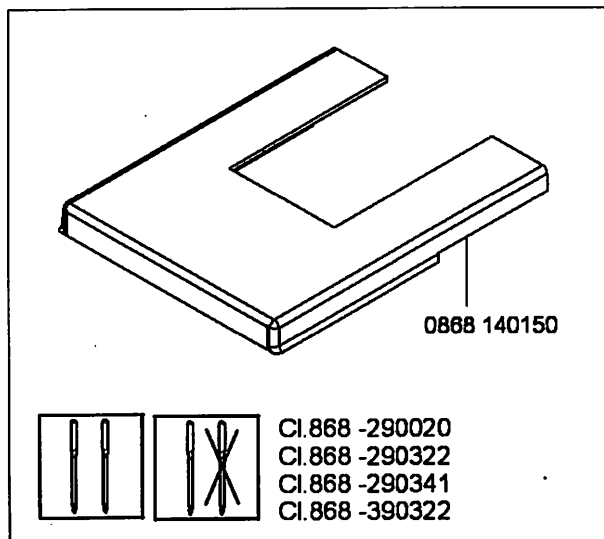
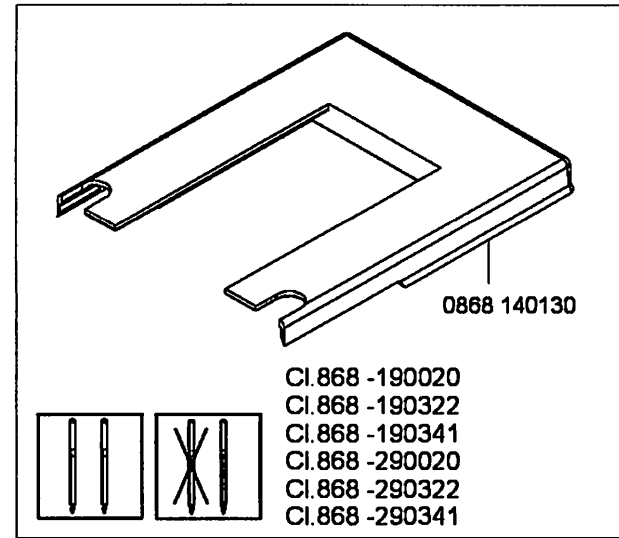
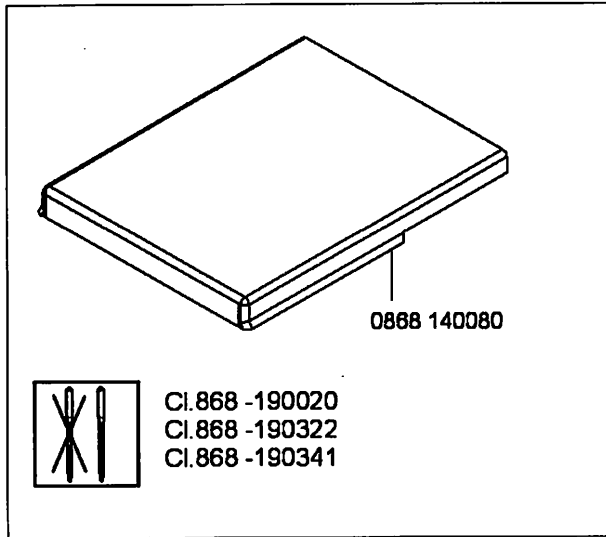

N - nicht als Einzelteil lieferbar  
 not available as separate part

CI. 868

Ausgabe/Edition 11.2008





Nummernschlüssel - Näheinrichtung der KI. 868  
Code numbers - Sewing equipment cl. 868

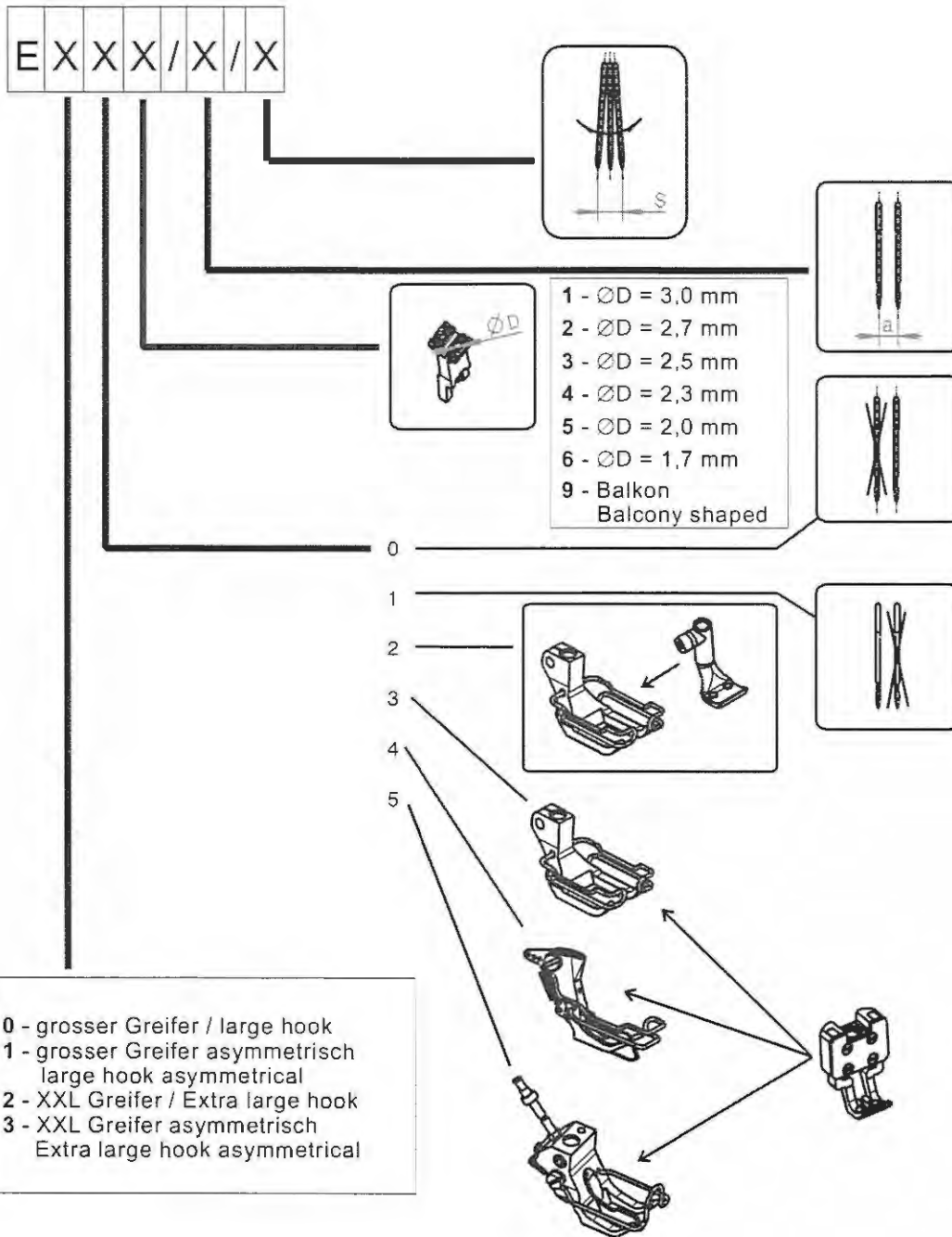

= Änderung / Modification



### Pneumatische Anschluss/Pneumatic connection

Die Näheinrichtungen E5x/xx/xx beinhalten auch die unten abgebildete Komponente.  
The following sewing equipments E5x/xx/xx include also the below reproduced component.

0867 590064

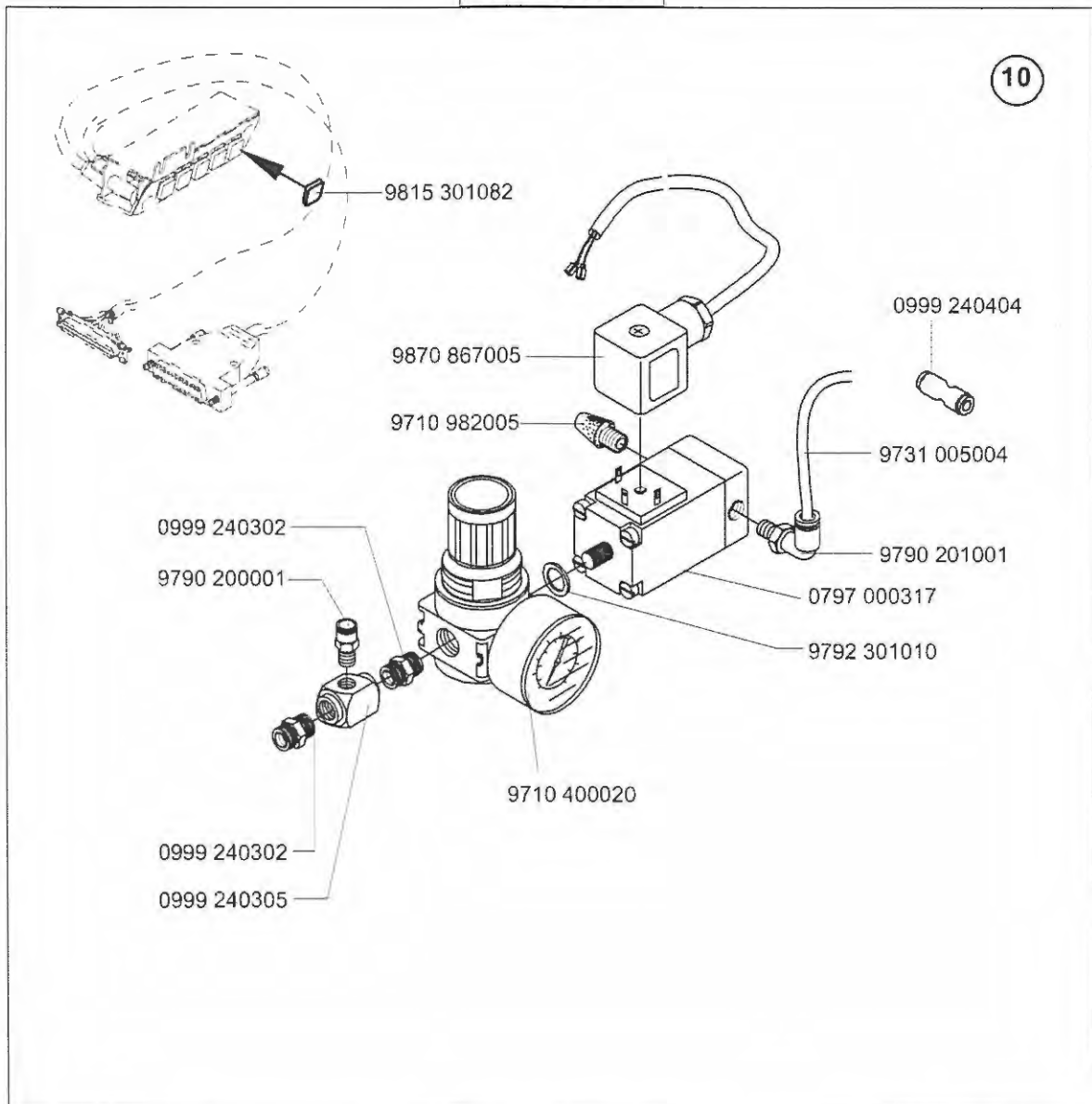

 = Änderung / Modification





E1/0/9  
E1/0/12  
E3/0/9

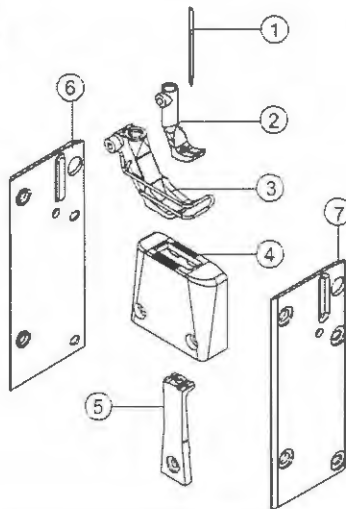

E9/0/6

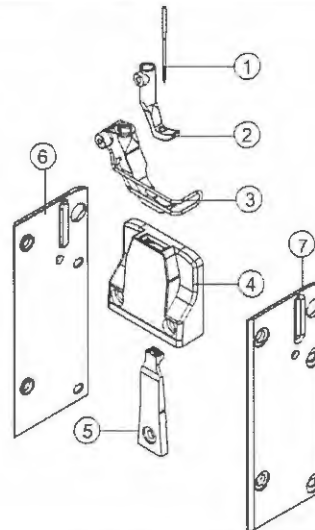

E11/0/9  
E13/0/9

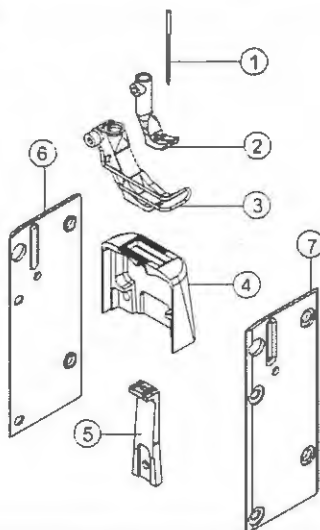

 = Änderung / Modification



E21/8/12  
E21/10/12  
E21/12/12  
E21/14/12

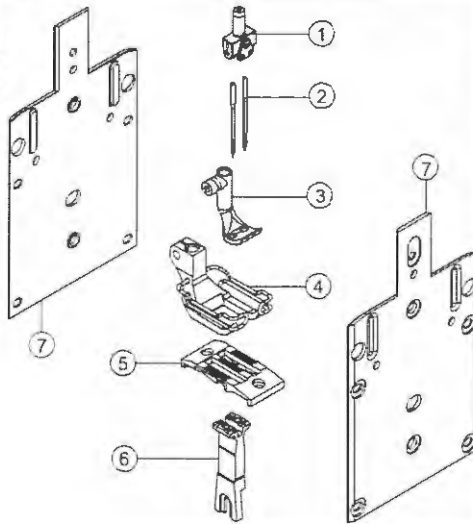

E31/8/12  
E31/10/12  
E31/12/12  
E31/14/12  
E33/4/6  
E33/6/9  
E33/8/9  
E33/10/9  
E33/12/9  
E33/14/9

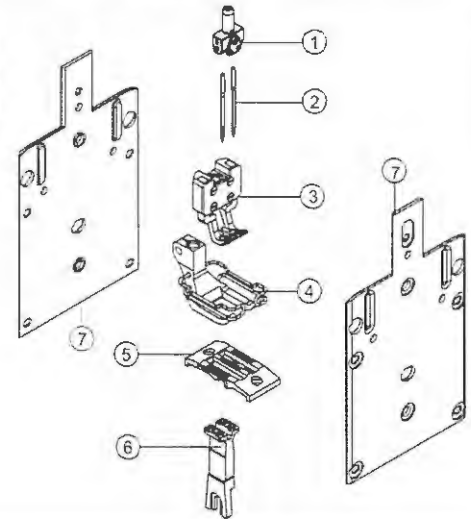

E41/12/9  
E43/5/9  
E43/6/9  
E43/8/9  
E43/10/9

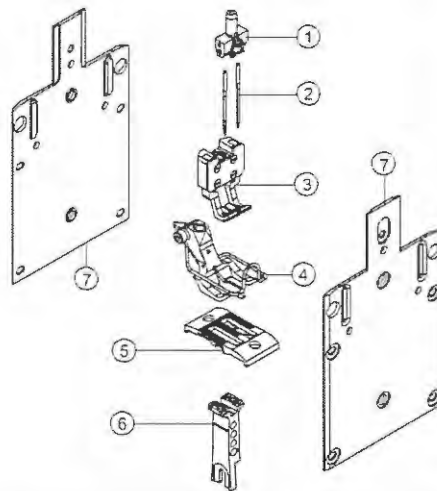

E51/8/9  
E51/10/9  
E51/12/9  
E53/5/9  
E53/6/9  
E53/8/9  
E53/10/9  
E53/12/9

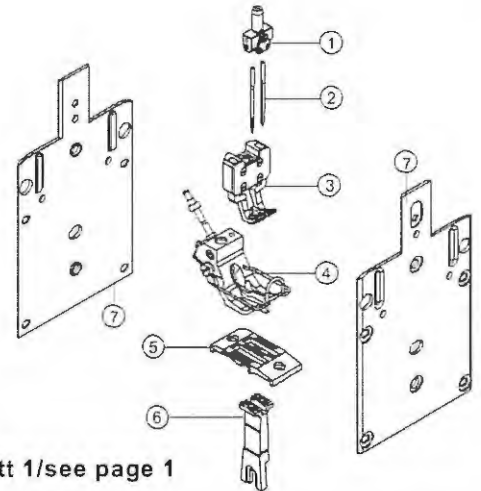

10  
siehe Blatt 1/see page 1

E453/6/9  
E453/8/9  
E453/10/9

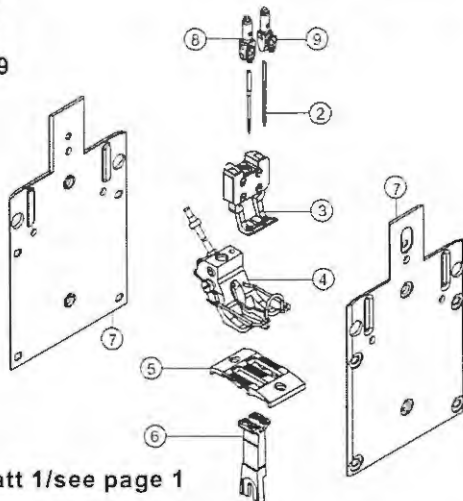

10  
siehe Blatt 1/see page 1

≙ Änderung / Modification



E-Nr. E-No. Abb.-Nr. Fig.No.	Für Unterklasse / For Subclass Verwendungszweck / Use	Material No. / Material Nr.	Stichplatte	Transporteur	Presserfuß	Transp. Fuß	⑥	⑦	①							
			Throat plate	Feed dog	Presser foot	Feeding foot										
			④	⑤	③	②										
			Stichplatte / Throat plate	Schieber, links / Slide, left	Schieber, rechts / Slide, right	Stichlochgröße / Stitch hole size mm	Sägeverzahnung / Serrated mm	Säge-schrägverzahnung / Serrated, oblique mm	Kreuzverzahnung / Cross toothed mm							
						Druckerfuß / Presser foot	Unverzahnung / Non toothed	Hüpfertfuß, kreuzverz. / Skipping f., cross toothed	Ausgleichfuß / Compensating foot							
						Kreuzverzahnung / Cross toothed mm	Unverzahnung / Non toothed	Kreuzverzahnung / Cross toothed mm	Unverzahnung / Non toothed							
							Seitenblech/Lateral cover	Seitenblech/Lateral cover	Nadelhalter/ Needle holder							
									Nadelsystem / -ctcke / Needle system / - size							
E 1/0/9	-190020; -190322 Näheinrichtung, Nadelstärke Nm 140-180, Stichlänge max. 9 mm, für mittelschweres Nähgut. Sewing equipment, needle size Nm 140-180, stitch length max. 9 mm, for medium weight material.	0868 E00109	0868 200030			Ø 3	0868 210010		0467 220043				0768 220113	0868 140020	0860 140030	134-35S/180
E 1/0/12	-190020; -190322 Näheinrichtung, Nadelstärke Nm 140-180, Stichlänge max. 12 mm, für mittelschweres Nähgut. Sewing equipment, needle size Nm 140-180, stitch length max. 12 mm, for medium weight material.	0868 E00112	0868 200040			Ø 3	0868 210010		0768 220013				0768 220113	0868 140020	0868 140030	134-35S/180
E 3/0/9	-190020; -190322 Näheinrichtung, Nadelstärke Nm 110-140, Stichlänge max. 9 mm, für mittelschweres Nähgut. Sewing equipment, needle size Nm 110-140, stitch length max. 9 mm, for medium weight material.	0868 E00309	0868 200030			Ø 2,5	0868 210030		0467 220043				0768 220113	0868 140020	0868 140030	134-35/140
E 9/0/6	-190020; -190322 Für kantennahe Näharbeiten mit besonders kleinen Radien in mittelschwerem Nähgut, Nadelstärke Nm 110-120, Stichlänge max. 6 mm. Sewing equipment for medium weight material, sewing operation on edges with small radius, Needle size Nm 110-120, Stitich length max. 6 mm.	0868 E00906	0868 200080			Ø 1,7	0860 210080		0768 220083				0768 220093	0868 140020	0868 140030	134-35/120
E 11/0/9	-390322 Näheinrichtung, Nadelstärke Nm 140-180, Stichlänge max. 9 mm, Linksgreifer, für mittelschweres Nähgut. Sewing equipment, needle size Nm 140-180, stitch length max. 9 mm, left hook, for medium weight material.	0868 E01109	0868 200060			Ø 3	0868 210050		0467 220043				0768 220113	0868 140020	0868 140030	134-35S/180
E 13/0/9	-390322 Näheinrichtung, Nadelstärke Nm 110-140, Stichlänge max. 9 mm, Linksgreifer, für mittelschweres Nähgut. Sewing equipment, needle size Nm 110-140, stitch length max. 9 mm, left hook, for medium weight material.	0868 E01309	0868 200060			Ø 2,5	0868 210070		0467 220043				0768 220113	0868 140020	0868 140030	134-35/140

☐ = Änderung / Modification





E-Nr. E-No.	Für Unterklasse / For Subclass	Material No. / Material Nr.	Stichplatte	Transporteur	Presserfuß	Transp.	⑦	①	②								
			Throat plate	Feed dog	Presser foot	Feeding foot											
Abb.-Nr. Fig.No.	Verwendungszweck / Use	Stichplatte / Throat plate	Schieber, links / Slide, left	Schieber, rechts / Slide, right	Stichlochgröße / Stich hole size	Sägeverzahnung / Serrated	Kreuzverzahnung / Cross toothed	Drückerfuß / Presser foot	Unverzahnung / Non toothed	Hüpfertfuß, kreuzverz. / Skipping f., cross toothed	Ausgleichfuß / Compensating foot	Kreuzverzahnung / Cross toothed	Unverzahnung / Non toothed	Nadelabstand / Needle distance	Seitenblech/Lateral cover	Nadelhalter/ Needle holder	Nadelsystem / -dicke / Needle-system / -size
E21/8/12	-290020; -290322; -290321 Näheinrichtung, Nadelabstand 8 mm, Nadelstärke Nm 140-180, Stichtlänge max. 12 mm, für mittelschweres Nähgut. Sewing equipment, needle gauge 8 mm, needle size Nm 140-180, stitch length max. 12 mm, for medium weight material.	0868 E02112 8	0868 202250		∅ 3	0868 212250		0768 222133					0768 222013	8	0868 142250	0867 230144	134-35S/180
E21/10/12	-290020; -290322; -290321 Näheinrichtung, Nadelabstand 10 mm, Nadelstärke Nm 140-180, Stichtlänge max. 12 mm, für mittelschweres Nähgut. Sewing equipment, needle gauge 10 mm, needle size Nm 140-180, stitch length max. 12 mm, for medium weight material.	0868 E02112 10	0868 202310		∅ 3	0868 212310		0768 222143					0768 222023	10	0868 142310	0867 230154	134-35S/180
E21/12/12	-290020; -290322; -290321 Näheinrichtung, Nadelabstand 12 mm, Nadelstärke Nm 140-180, Stichtlänge max. 12 mm, für mittelschweres Nähgut. Sewing equipment, needle gauge 12 mm, needle size Nm 140-180, stitch length max. 12 mm, for medium weight material.	0868 E02112 12	0868 202370		∅ 3	0868 212370		0768 222153					0768 222033	12	0868 142370	0867 230164	134-35S/180
E21/14/12	-290020; -290322; -290321 Näheinrichtung, Nadelabstand 14 mm, Nadelstärke Nm 140-180, Stichtlänge max. 12 mm, für mittelschweres Nähgut. Sewing equipment, needle gauge 14 mm, needle size Nm 140-180, stitch length max. 12 mm, for medium weight material.	0868 E02112 14	0868 202430		∅ 3	0868 212430		0768 222163					0768 222043	14	0868 142430	0867 230174	134-35S/180
E31/8/12	-290020; -290322; -290321 Näheinrichtung, Nadelabstand 8 mm, Nadelstärke Nm 140-180, Stichtlänge max. 12 mm, für mittelschweres Nähgut. Sewing equipment, needle gauge 8 mm, needle size Nm 140-180, stitch length max. 12 mm, for medium weight material.	0868 E03112 8	0868 202250		∅ 3	0868 212250		0768 222133			0768 222374			8	0868 142250	0867 230144	134-35S/180
E31/10/12	-290020; -290322; -290321 Näheinrichtung, Nadelabstand 10 mm, Nadelstärke Nm 140-180, Stichtlänge max. 12 mm, für mittelschweres Nähgut. Sewing equipment, needle gauge 10 mm, needle size Nm 140-180, stitch length max. 12 mm, for medium weight material.	0868 E03112 10	0868 202310		∅ 3	0868 212310		0768 222143			0768 222404			10	0868 142310	0867 230154	134-35S/180

■ = Änderung / Modification



E-Nr. E-No.	Für Unterklasse / For Subclass	Abb.-Nr. Fig.No.	Verwendungszweck / Use	Material No. / Material Nr.	Stichplatte	Transporteur	Presserfuß	Transp. Fuß	⑦	①	②										
					Throat plate	Feed dog ⑥	Presser foot ④	Feeding foot ③													
					⑤																
					Stichplatte / Throat plate	Schieber, links / Slide, left	Schieber, rechts / Slide, right	Stichlochgröße / Stitch hole size mm	Sägeverzahn / Serrated mm	Säge-schrägverzahn / Serrated, oblique mm	Kreuzverzahn / Cross toothed mm	Drückerfuß / Presser foot	Unverzahn / Non-toothed	Hüpfertuß, kreuzverz. / Skipping f., cross toothed	Ausgleichfuß / Compensating foot	Kreuzverzahn / Cross toothed mm	Unverzahn / Non-toothed	Nadelabstand / Needle distance	Seitenblech/Lateral cover	Nadelhalter/ Needle holder	Nadelsystem / -dicke / Needle system / -size
E31/12/12	-290020; -290322; -290321 Näheinrichtung, Nadelabstand 12 mm, Nadelstärke Nm 140-180. Stichlänge max. 12 mm, für mittelschweres Nähgut. Sewing equipment, needle gauge 12 mm, needle size Nm 140-180, stitch length max. 12 mm, for medium weight material.			0868 E03112 12	0868 202370			∅ 3	0868 212370			0768 222153			0768 222434			12	0868 142370	0867 230164	134-35S/180
E31/14/12	-290020; -290322; -290321 Näheinrichtung, Nadelabstand 14 mm, Nadelstärke Nm 140-180. Stichlänge max. 12 mm, für mittelschweres Nähgut Sewing equipment, needle gauge 14 mm, needle size Nm 140-180, stitch length max. 12 mm, for medium weight material.			0868 E03112 14	0868 202430			∅ 3	0868 212430			0768 222163			0768 222464			14	0868 142430	0867 230174	134-35S/180
E33/4/6	-290020; -290322; -290321 Näheinrichtung, Nadelabstand 4 mm, Nadelstärke Nm 110-140, Stichlänge max. 6 mm, für mittelschweres Nähgut. Sewing equipment, needle gauge 4 mm, needle size Nm 110-140, stitch length max. 6 mm, for medium weight material.			0868 E03306 4	0868 202090			∅ 2,5	0868 212070			0367 222473			0868 222114			4	0868 142070	0867 230114	134-35/140
E33/6/9	-290020; -290322; -290321 Näheinrichtung, Nadelabstand 6 mm, Nadelstärke Nm 110-140, Stichlänge max. 9 mm, für mittelschweres Nähgut. Sewing equipment, needle gauge 6 mm, needle size Nm 110-140, stitch length max. 9 mm, for medium weight material.			0868 E03309 6	0868 202200			∅ 2,5	0868 212210			0768 222123			0768 222264			6	0868 142190	0867 230134	134-35/140
E33/8/9	-290020; -290322; -290321 Näheinrichtung, Nadelabstand 8 mm, Nadelstärke Nm 110-140, Stichlänge max. 9 mm, für mittelschweres Nähgut. Sewing equipment, needle gauge 8 mm, needle size Nm 110-140, stitch length max. 9 mm, for medium weight material.			0868 E03309 8	0868 202260			∅ 2,5	0868 212270			0768 222133			0768 222274			8	0868 142250	0867 230144	134-35/140
E33/10/9	-290020; -290322; -290321 Näheinrichtung, Nadelabstand 10 mm, Nadelstärke Nm 110-140, Stichlänge max. 9 mm, für mittelschweres Nähgut. Sewing equipment, needle gauge 10 mm, needle size Nm 110-140, stitch length max. 9 mm, for medium weight material.			0868 E03309 10	0868 202320			∅ 2,5	0868 212330			0768 222143			0768 222284			10	0868 142310	0867 230154	134-35/140

■ = Änderung / Modification





E-Nr. E-No.	Für Unterklasse / For Subclass	Material No. / Material Nr.	Stichplatte	Transporteur	Presserfuß	Transp. Fuß												
			Throat plate	Feed dog	Presser foot	Feeding foot	⑤	⑥	④	③	⑦	①	②					
Abb.-Nr. Fig.No.	Verwendungszweck / Use	Stichplatte / Throat plate	Schieber, links / Slide, left	Schieber, rechts / Slide, right	Stichlochgröße / Stitch hole size mm	Sägeverzahn / Serrated mm	Säge-schrägverzahn / Serrated, oblique mm	Kreuzverzahn / Cross toothed mm	Drückenfuß / Presser foot	Unverzahn / Non toothed	Hüpfertfuß, kreuzverz. / Skipping f., cross toothed	Ausgleichfuß / Compensating foot	Kreuzverzahn / Cross toothed mm	Unverzahn / Non toothed	Nadelabstand / Needle distance	Seitenblech/Lateral cover	Nadelhalter/ Needle holder	Nadelsystem / -dicke / Needle system / -size
E33/12/9	-290020; -290322; -290321 Näheinrichtung, Nadelabstand 12 mm, Nadelstärke Nm 110-140, Stichtlänge max. 9 mm, für mittelschweres Nähgut. Sewing equipment, needle gauge 12 mm, needle size Nm 110-140, stitch length max. 9 mm, for medium weight material.	0868 E03309 12	0868 202380		∅ 2,5	0868 212390			0768 222153			0768 222294			12	0868 142370	0867 230164	134-35/140
E33/14/9	-290020; -290322; -290321 Näheinrichtung, Nadelabstand 14 mm, Nadelstärke Nm 140-180, Stichtlänge max. 9 mm, für mittelschweres Nähgut Sewing equipment, needle gauge 14 mm, needle size Nm 140-180, stitch length max. 9 mm, for medium weight material.	0868 E03309 14	0868 202440		∅ 2,5	0868 212450			0768 222163			0768 222464			14	0868 142430	0867 230174	134-35/140

= Änderung / Modification





E-Nr. E-No. Abb.-Nr. Fig.No.	Für Unterklasse / For Subclass Verwendungszweck / Use	Material No. / Material Nr.	Stichplatte	Transporteur	Presserfuß	Transp.													
			Throat plate	Feed dog	Presser foot	Feeding foot	⑤	⑥	④	③	⑦	①	②						
			Stichplatte / Throat plate	Schieber, links / Slide, left	Schieber, rechts / Slide, right	Stichlochgröße / Stitch hole size mm	Sägeverzahn / Serrated mm	Säge-schrägverzahn / Serrated, oblique mm	Kreuzverzahn / Cross toothed mm	Drückerfuß / Presser foot	Unverzahn / Non toothed	Hüpfertfuß, kreuzverz. / Skipping f., cross toothed	Ausgleichfuß / Compensating foot	Kreuzverzahn / Cross toothed mm	Unverzahn / Non toothed	Nadelabstand / Needle distance	Seitenblech/Lateral cover	Nadelhalter/ Needle holder	Nadelsystem / -dicke / Needle system / -size
E41/12/9	-290020; -290322; -290321 Näheinrichtung, Nadelabstand 12 mm, Nadelstärke Nm 140-180, Stichtlänge max. 9 mm, für mittelschweres Nähgut. Sewing equipment, needle gauge 12 mm, needle size Nm 140-180, stitch length max. 9 mm, for medium weight material.	0868 E04109 12	0868 202380			∅ 3	0868 212370			0868 222084			0768 222434			12	0868 142370	0867 230164	134-35S/180
E43/5/9	-290020; -290322; -290321 Näheinrichtung, Nadelabstand 5 mm, Nadelstärke Nm 110-140, Stichtlänge max. 9 mm, für mittelschweres Nähgut. Sewing equipment, needle gauge 5 mm, needle size Nm 110-140, stitch length max. 9 mm, for medium weight material.	0868 E04309 5	0868 202140			∅ 2,5	0868 212150			0868 222034			0868 222124			5	0868 142130	0867 230124	134-35/140
E43/6/9	-290020; -290322; -290321 Näheinrichtung, Nadelabstand 6 mm, Nadelstärke Nm 110-140, Stichtlänge max. 9 mm, für mittelschweres Nähgut. Sewing equipment, needle gauge 6 mm, needle size Nm 110-140, stitch length max. 9 mm, for medium weight material.	0868 E04309 6	0868 202200			∅ 2,5	0868 212210			0868 222044			0768 222264			6	0868 142190	0867 230134	134-35/140
E43/8/9	-290020; -290322; -290321 Näheinrichtung, Nadelabstand 8 mm, Nadelstärke Nm 110-140, Stichtlänge max. 9 mm, für mittelschweres Nähgut. Sewing equipment, needle gauge 8 mm, needle size Nm 110-140, stitch length max. 9 mm, for medium weight material.	0868 E04309 8	0868 202260			∅ 2,5	0868 212270			0868 222064			0768 222274			8	0868 142250	0867 230144	134-35/140
E43/10/9	-290020; -290322; -290321 Näheinrichtung, Nadelabstand 10 mm, Nadelstärke Nm 110-140, Stichtlänge max. 9 mm, für mittelschweres Nähgut. Sewing equipment, needle gauge 10 mm, needle size Nm 110-140, stitch length max. 9 mm, for medium weight material.	0868 E04309 10	0868 202320			∅ 2,5	0868 212330			0868 222074			0768 222284			10	0868 142310	0867 230154	134-35/140

■ = Änderung / Modification



Näheinrichtungen  
Sewing equipment

868

E-Nr. E-No. Abb.-Nr. Fig.No.	Für Unterklasse / For Subclass Verwendungszweck / Use	Material No. / Material Nr.	Stichplatte	Transporteur	Presserfuß	Transp.	Nadelabstand/Needle distance	Seitenblech/Lateral cover	Nadelhalter/ Needle holder	Nadelsystem / -dicke / Needle system / -size									
			Throat plate	Feed dog	Presser foot	Fuß Feeding foot													
			Stichplatte / Throat plate	Schieber, links / Slide, left	Schieber, rechts / Slide, right	Stichlochgröße / Stich hole size mm	Sägeverzahn / Serrated mm	Säge-schrägverzahn / Serrated, oblique mm	Kreuzverzahn / Cross toothed mm	Drückerfuß / Presser foot	Unverzahn / Non toothed	Hüpfenfuß, kreuzverz. / Skipping f., cross toothed	Ausgleichfuß / Compensating foot	Kreuzverzahn / Cross toothed mm	Unverzahn / Non toothed				
E51/8/9	-290020*; -290322; -290321 Näheinrichtung, Nadelabstand 8 mm, Nadelstärke Nm 140-180, Stichtlänge max. 9 mm, für mittelschweres Nähgut. Sewing equipment, needle gauge 8 mm, needle size Nm 140-180, stitch length max. 9 mm, for medium weight material.	0868 E05109 8	0868 202260			∅ 3	0868 212250			0768 222674			0768 222374			8	0868 142250	0867 230144	134-35S/180
E51/10/9	-290020*; -290322; -290321 Näheinrichtung, Nadelabstand 10 mm, Nadelstärke Nm 140-180, Stichtlänge max. 9 mm, für mittelschweres Nähgut. Sewing equipment, needle gauge 10 mm, needle size Nm 140-180, stitch length max. 9 mm, for medium weight material.	0868 E05109 10	0868 202320			∅ 3	0868 212310			0768 222684			0768 222404			10	0868 142310	0867 230154	134-35S/180
E51/12/9	-290020*; -290322; -290321 Näheinrichtung, Nadelabstand 12 mm, Nadelstärke Nm 140-180, Stichtlänge max. 9 mm, für mittelschweres Nähgut. Sewing equipment, needle gauge 12 mm, needle size Nm 140-180, stitch length max. 9 mm, for medium weight material.	0868 E05109 12	0868 202380			∅ 3	0868 212370			0768 222694			0768 222434			12	0868 142370	0867 230164	134-35S/180
E53/5/9	-290020*; -290322; -290321 Näheinrichtung, Nadelabstand 5 mm, Nadelstärke Nm 110-140, Stichtlänge max. 9 mm, für mittelschweres Nähgut. Sewing equipment, needle gauge 5 mm, needle size Nm 110-140, stitch length max. 9 mm, for medium weight material.	0868 E05309 5	0868 202140			∅ 2.5	0868 212150			0868 222024			0868 222124			5	0868 142130	0867 230124	134-35/140
E53/6/9	-290020*; -290322; -290321 Näheinrichtung, Nadelabstand 6 mm, Nadelstärke Nm 110-140, Stichtlänge max. 9 mm, für mittelschweres Nähgut. Sewing equipment, needle gauge 6 mm, needle size Nm 110-140, stitch length max. 9 mm, for medium weight material.	0868 E05309 6	0868 202200			∅ 2.5	0868 212210			0768 222664			0768 222264			6	0868 142190	0867 230134	134-35/140

\* kann als Sonderanfertigung angefragt werden nur in Verbindung mit DC1550  
\* only with DC1550

= Änderung / Modification





E-Nr. E-No. Abb.-Nr. Fig.No.	Für Unterklasse / For Subclass Verwendungszweck / Use	Material No. / Material Nr.	Stichplatte	Transporteur	Presserfuß	Transp. Fuß												
			Throat plate	Feed dog	Presser foot	Feeding foot	⑤	⑥	④	③	⑦	①	②					
			Schieber, links / Slide, left	Schieber, rechts / Slide, right	Stichlochgröße / Stitch hole size mm	Sägeverzahnung / Serrated mm	Säge-schrägverzahnung / Serrated, oblique mm	Kreuzverzahnung / Cross toothed mm	Drückerfuß / Presser foot	Unverzahnung / Non toothed	Hüpfertuß, kreuzverz. / Skipping f., cross toothed	Ausgleichfuß / Compensating foot	Kreuzverzahnung / Cross toothed mm	Unverzahnung / Non toothed	Nadelabstand / Needle distance	Seitenblech / Lateral cover	Nadelhalter / Needle holder	Nadelsystem / -dicke / Needle system / -size
E53/8/9	-290020*; -290322; -290321 Näheinrichtung, Nadelabstand 8 mm, Nadelstärke Nm 110-140, Stichtlänge max. 9 mm, für mittelschweres Nähgut. Sewing equipment, needle gauge 8 mm, needle size Nm 110-140, stitch length max. 9 mm, for medium weight material.	0868 E05309 8 0868 202260			∅ 2,5	0868 212270			0768 222674			0768 222274			8	0868 142250	0867 230144	134-35/140
E53/10/9	-290020*; -290322; -290321 Näheinrichtung, Nadelabstand 10 mm, Nadelstärke Nm 110-140, Stichtlänge max. 9 mm, für mittelschweres Nähgut. Sewing equipment, needle gauge 10 mm, needle size Nm 110-140, stitch length max. 9 mm, for medium weight material.	0868 E05309 10 0868 202320			∅ 2,5	0868 212330			0768 222684			0768 222284			10	0868 142310	0867 230154	134-35/140
E53/12/9	-290020*; -290322; -290321 Näheinrichtung, Nadelabstand 12 mm, Nadelstärke Nm 110-140, Stichtlänge max. 9 mm, für mittelschweres Nähgut. Sewing equipment, needle gauge 12 mm, needle size Nm 110-140, stitch length max. 9 mm, for medium weight material.	0868 E05309 12 0868 202380			∅ 2,5	0868 212390			0768 222694			0768 222294			12	0868 142370	0867 230164	134-35/140

\* kann als Sonderanfertigung angefragt werden nur in Verbindung mit DC1550  
\* only with DC1550

■ = Änderung / Modification



E-Nr. E-No.	Für Unterklasse / For Subclass	Material No. / Material Nr.	Stichplatte	Transporteur	Presserfuß	Transp. Fuß						
			Throat plate	Feed dog	Presser foot	Feeding foot	Stichplatte	Transporteur	Presserfuß	Transp. Fuß		
Abb.-Nr. Fig.No.	Verwendungszweck / Use		⑤					⑦	⑧	⑨	⑩	
E453/6/9	-490322 Näheinrichtung, Nadelabstand 6 mm, schaltbare Nadelstangen, Nadelstärke Nm 110-140, Stichlänge max. 9 mm, für mittelschweres Nähgut. Sewing equipment, needle gauge 6 mm, needle bar rocking mechanism, needle size Nm 110-140, stitch length max. 9 mm, for medium weight material.	0868 E45309 6 0868 202200		∅ 2,5	0868 212210	0768 222664	0768 222264	6	0868 142190	0867 230554	0867 230544	134-35/140
E453/8/9	-490322 Näheinrichtung, Nadelabstand 8 mm, schaltbare Nadelstangen, Nadelstärke Nm 110-140, Stichlänge max. 9 mm, für mittelschweres Nähgut. Sewing equipment, needle gauge 8 mm, needle bar rocking mechanism, needle size Nm 110-140, stitch length max. 9 mm, for medium weight material.	0868 E45309 8 0868 202260		∅ 2,5	0868 212270	0768 222674	0768 222274	8	0868 142250	0867 230534	0867 230524	134-35/140
E453/10/9	-490322 Näheinrichtung, Nadelabstand 10 mm, schaltbare Nadelstangen, Nadelstärke Nm 110-140, Stichlänge max. 9 mm, für mittelschweres Nähgut. Sewing equipment, needle gauge 10 mm, needle bar rocking mechanism, needle size Nm 110-140, stitch length max. 9 mm, for medium weight material.	0868 E45309 10 0868 202320		∅ 2,5	0868 212330	0768 222684	0768 222284	10	0868 142310	0867 230514	0867 230504	134-35/140

■ = Änderung / Modification

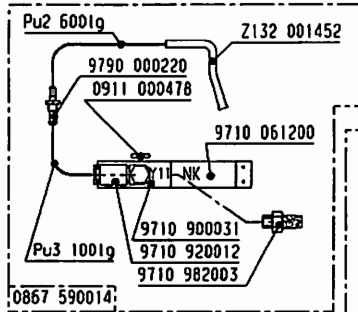
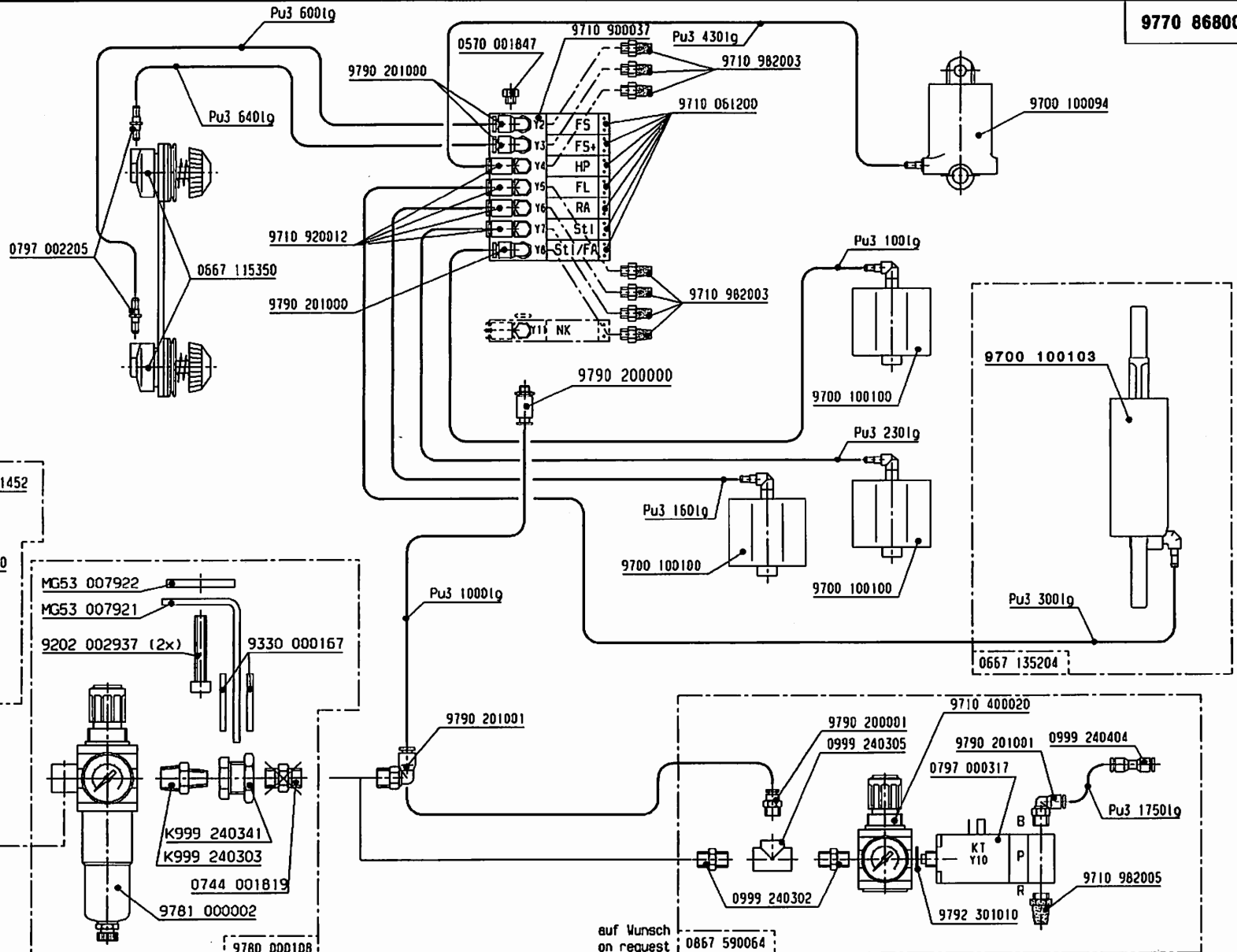

0867 590014:  
auf Wunsch  
on request

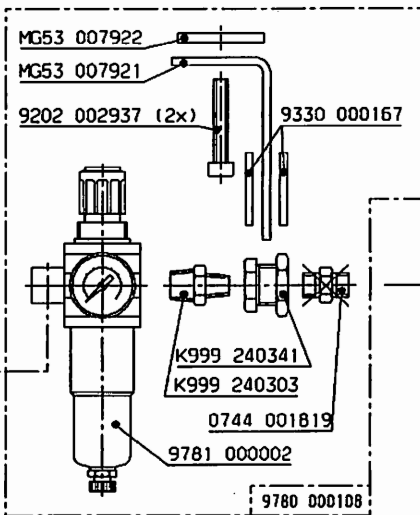

auf Wunsch  
on request

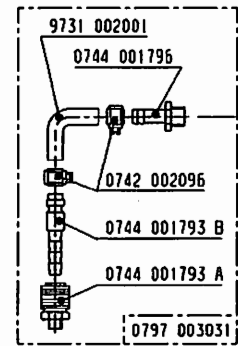

auf Wunsch  
on request

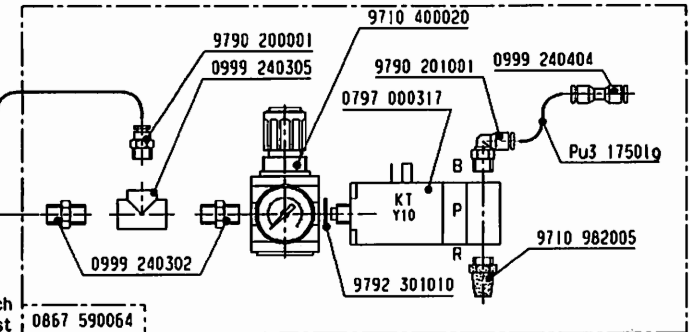

auf Wunsch  
on request

Schlauch Hose	Teile-Nr. (Meterware) Part-No. (Yarded goods)
PU2	0699 979265
PU3	9731 005004

And.	Datum	gez.	gepr.
	14.02.08	gez.	Schmid
	13.01.10	gez.	Riffel
		gez.	

Pneu.-Geräteplan für  
Pneu.-Elements-Plan for  
0868-1903.. 0868-3903..  
0868-2903..

DÜRKOPP ADLER AG	
9770 868001	
Blatt 1	Blattz. 2

9770 868001

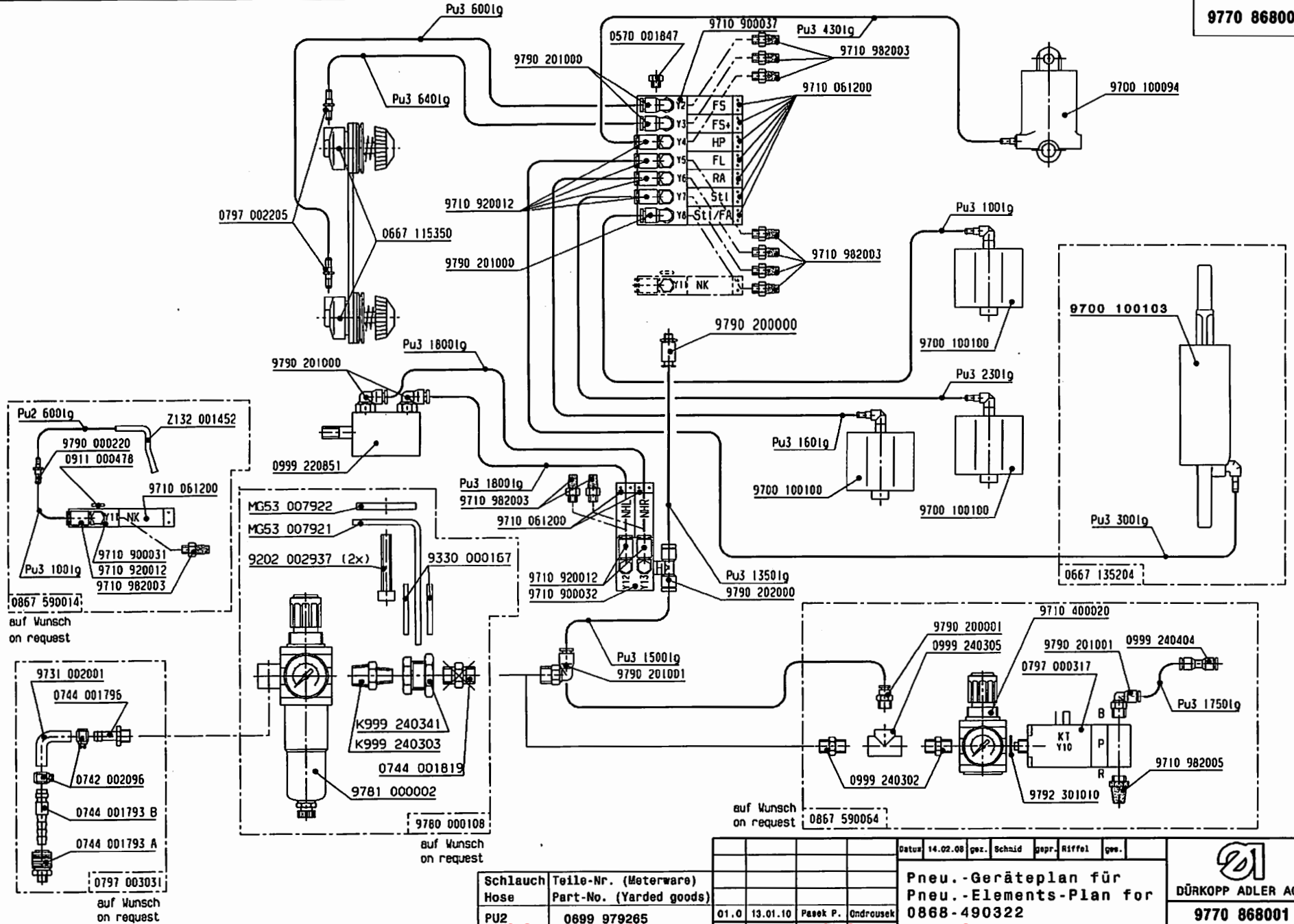

Schlauch Hose	Teile-Nr. (Meterware) Part-No. (Yarded goods)				
PU2	0699 979265	01.0	13.01.10	Pasek P.	Ondrousek
PU3	0699 979265				

Datum 14.02.08  
 Pneu.-Geräteplan für  
 Pneu.-Elements-Plan for  
 0868-490322

**DÜRKOPP ADLER AG**  
 9770 868001  
 Blatt 2 Blattz. 2

Schutzmerk  
 DIN 150 16016 beachten  
 A3